



- **Compact and robust design for mechanical engineering and industrial plant applications**
- **PNO Profisafe Certificate No. Z20020**
- **SIL2 according to TÜV certificate Nr. 44 207 11 391019-001**
- **With PROFIsafe Interface to PROFIsafe-Profile for Safety Technology, Version 1.30, No. 3.092/ Version 2.00, No.3.192 (PNO)**
- **DP-Slave Class 2 functionality in accordance with Profibus-Profile for Encoder, No. 3.060 (PNO)**
- **Total number of positions: 2²⁵ (25 bits) max.**
- **With Velocity signal depending on rotation sense, gating time adjustable**
- **SIL2 Certificate in preparation**
- **Operating speed up to 2500 min⁻¹**
- **Optional: Flange, housing and connecting cap in stainless steel - series "SRD"**



- **Protection grade IP 65 or IP 66**
- **Diagnosis LED's for supply voltage, SRD, Class 2 and Error**

General description

The encoder CRD/S3 has been designed according to the PROFIsafe profile for safety technology to the PNO standards No. 3.092/ 3.192 (PNO). The protocol meets the DP slave class 2 functionality to PNO No. 3.060 and is described in the TWK user manual no. CRD 12099.

In addition to the angle position a velocity measurement signal is generated via the position data. The gating time of the velocity measurement is adjustable in the range of 1...255 ms.

The PROFIsafe-Profile has been developed for safety relevant applications where human lives and environmental objects may be exposed to danger. In case of any unexpected event the device should revert to a fail-safe operation. To comply with this requirement the model CRS/S3 encoders feature additional surveillance functions which are described in the manual no. CRD 12099.

The SPC3 Siemens PROFIBUS controller has been implemented at the output interface. The maximum data transmission rate is 12 Mbaud.

To guaranty a fail safe operation, a fail safe master, e.g. Siemens F-CPU with S7 Distributed Safety must be used.

Because of different parameter and diagnosis data the CRD/S3 ist not compatible to the preceding model CRD/S2.

Construction

Flange and housing of aluminium - respectiny stainless steel for SRD series - 12 mm ball-bearings with Nilos ring seal or radial packing ring seal - code disk of glass or of deformation resistant plastic - GaAIAs diodes - photo-transistor array with comparator and trigger circuits for long-term stabilization of the sensor systems gate array - SMD technology - additional implementations for safety functions to comply with SIL2 to IEC 61508.

Connecting cap

T-coupler functionality with integrated addressing code

Connection leads and functions:

- 1 cable for the supply voltage (+ V_s = 24 VDC, - V_s = 0 VDC), M12 cable gland
- 1 cable for Bus in (A, B), M16 cable gland
- 1 cable for Bus out (A', B'), M16 cable gland
- The station address and bus-termination resistors are set with DIP switches in the connecting cap.

Electrical data

- Sensor system: GaAlAs diodes, photo-transistor array
- Resolution (max.): 8192 positions per revolution
- Measuring range: 4096 revolutions
- Total number of positions: 2^{25} (25 bits max.)
- Graduation code: Gray
- Max. position variance: $\leq \pm 2' 38''$ at 4096 positions/rev.
 $\leq \pm 1' 59''$ at 8192 positions/rev.
- Output code: Natural binary
- Velocity signal: depending on rotation sense, 16 bit, unit: steps/gating time (the gating time is programmable in the range of 1 to 255 ms, default: 10 ms)
- Code sense: CW or CCW; (programmable)
- Supply voltage range: + 13,5 VDC to + 30 VDC
- Power consumption: $P_D \leq 3,5 \text{ W}$ (Inrush current $\leq 300 \text{ mA}$)
- Interface: Line driver in acc. with RS 485; galvanic separation is achieved with an opto-coupler. Supply voltage galvanic separation is achieved with DC/DC-converter
- Electromagnetic compatibility (EMC): EN 61000-4-2 (ESD)
EN 61000-4-4 (Burst)
EN 61000-6-4 (Emission)

Bus data

- Specification: PROFIsafe-Profile for Safety Technology (No. 3.092/ 3.192 - PNO)
Profibus-Profile for Encoder (No. 3.060 - PNO)
- Data transmission rate: 9,6 kBaud to 12 MBaud
- Manufacturer code: 1962h
- Stations address: 1 to 126
Default value: 123
adjustable via DIP switches
in acc. with DIN 19245-3, PROFIBUS-DP
- GSD File:
- Diagnosis LED's*: U_B (green) - Supply voltage
SRD (green) - SRD
C (green) - Class
Err (red) - Error
- Freeze mode: not supported
- Sync mode: not supported
- Automatic baud rate search: being supported
- Diagnosis bytes Class 2: 66 Diagnosis bytes
- User-Parameterbytes Class 2: 45 Bytes
- Configuration options: PROFIsafe, Class 2 -Encoder

* True table according to the connector arrangement will be supplied with each item.

Safety Data (IEC61508)

- According to IEC 61508:
 - PFH = $4,35 \times 10^{-7} \text{ 1/h}$
 - SFF = 98 %
 - HFT = 0
 - SIL2
- According to EN ISO 13849-1:
 - $MTTF_D > 100 \text{ years}$
 - DC = 98 %
 - Category 2
 - Performance Level D
- Maximum service life: 20 years

Mechanical data

- Operating speed: $2500 \text{ min}^{-1} \text{ max}$
- Angular acceleration: $10^5 \text{ rad/s}^2 \text{ max.}$
- Moment of inertia (rotor): 45 gcm^2
- Operating torque: $\leq 5 \text{ Ncm}$ (8 Ncm - CRD66)
(at 1000 rpm)
- Starting torque: $\leq 1 \text{ Ncm}$ (4 Ncm - CRD66)
- Permissible shaft load: 250 N max. (axial and radial)
- Bearing life expectancy: $10^9 \text{ revolutions}^*$
- Mass
CRD 58, 65 and 66: ca. 0.7 kg with connecting cap
CRD 105: ca. 1.4 kg with connecting cap

* At max. shaft load and working temperature between - 20 °C and + 60 °C. Higher values are permissible with lower loads.

Environmental data

- Operating temperature range: - 20 °C to + 60 °C
- Storage temperature range: - 20 °C to + 60 °C
- Permissible rel. humidity: 85 % without condensation
- Resistance to shock: 200 m/s^2 ; 6 ms (DIN IEC 68)
- Resistance to vibration: 5 Hz to 2000 Hz; 100 m/s^2 (DIN IEC 68)
- Protection grade (DIN 40 050)
 - CRD 58, 65 and 105: IP 65 (Nilos ring)
 - CRD 66: IP 66 (radial packing ring)
 - Connecting cap: IP 00 (when not mounted)

Programming parameter: Encoder

| Parameter | Range of values | Parameter description |
|------------------------------------|-------------------------------------|--|
| Code sense | CW, CCW | Direction of rotation when looking towards the shaft: CW (clockwise), CCW (counter clockwise) |
| Scaling function | disable, enable | Enable for programming the parameters <i>Resolution and Total number of positions</i> and of the preset function |
| Resolution | 2 to 8192 Positions/360° | Number of positions per revolution |
| Total number of positions | 2 to 33.554.432 | Total number of positions in steps (Total number of positions = resolution x number of turns) |
| Gating time | 1 to 255 ms | Time intervall for the counting of steps of the speed measurement |
| Standard Parameter CRC | 1 to FFFF | CRC-Checksum of standard parameters |
| Reference value (by data exchange) | 0 to (Total number of positions -1) | Value displayed at the reference point |

Programme for calculating the CRC checksum via the standard parameters

After changing an encoder parameter, the CRC checksum has to be re-calculated and entered in the "Standard Parameter CRC" parameter. The programme PsCrc.exe for calculating the CRC checksum is available for download on www.twk.de.

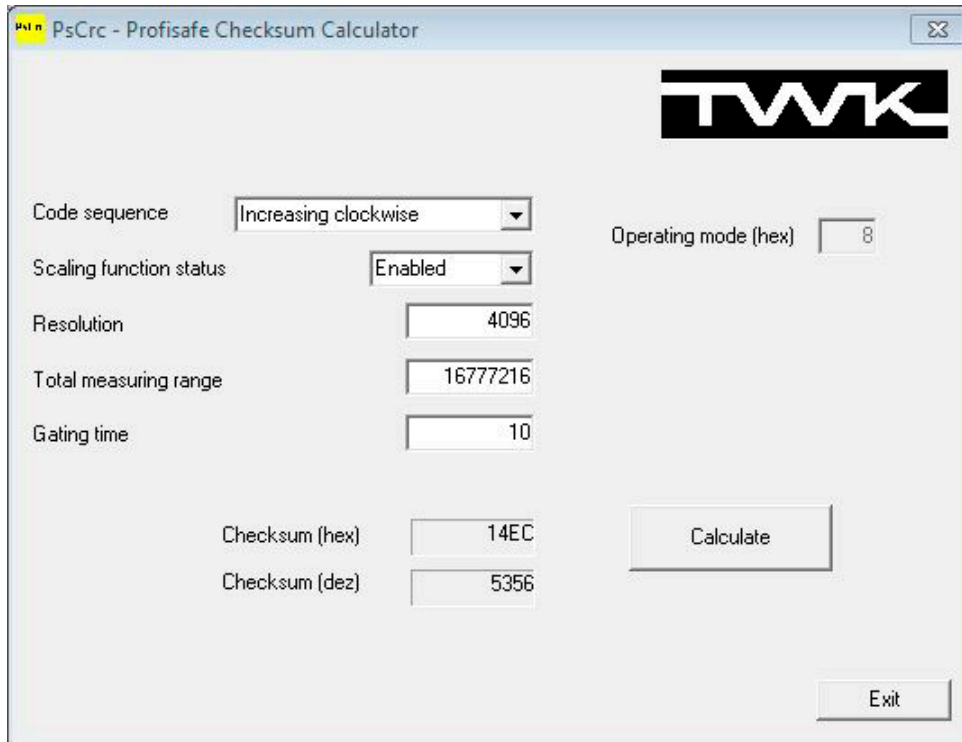

Programming parameter: F-Parameter

| Parameter | Range of values | Default | Parameter description |
|------------------------|---|---------------|---|
| F_Check_SeqNr | 0: NoCheck | NoCheck | This parameter defines whether or not the consecutive number shall be included in the CRC2 signature. |
| F_Check_iPar | 0: NoCheck | NoCheck | This parameter defines whether or not the checksum of the individual parameters CRC3 shall be included in the CRC2 signature. |
| F_SIL | 01b: SIL2 | SIL2 | SIL2 (Safety Integrity Level) to IEC 61508 (Functional safety of electrical/ electronic/programmable electronic safety-related systems) |
| F_CRC_Length | 00b: 3-Byte-CRC (V2-Mode) 01b: 2-Byte-CRC (V1-Mode) 10b: 4-Byte-CRC (optional V1/ V2 Mode) | 2-Byte-CRC | CRC Test value (of F- useful data) |
| F_Block_ID | No F_iPar_CRC | No F_iPar_CRC | fix adjusted |
| F_Par_Version | 00b: V1-mode 01b: V2-mode | V1-mode | Parameter version |
| F_Source_Add | 1-65534 | 2001 | This parameter is allocated through the SIMATIC manager automatically. |
| F_Dest_Add | 1-65534 | 123 | This parameter must agree with the address in the connecting cap. |
| F_WD_Time | 1-65536 ms | 2000 | A valid current Safety telegram from the F-CPU must come inside the watchdog time. |
| F_ParCRC (CRC1) | 0-65535 | | CRC-Sum of the F-Parameter from F_Prm_Flag1 |

Data format

Output data: Host to slave

| Octet 1 | Octet 2 | Octet 3 | Octet 4 | Octet 5 | Octet 6 | Octet 7 | Octet 8 | Octet 9 | Octet 10 |
|--------------------|---------|---------|---------|---------------|---------|---------|---------|---------|----------|
| MSB * Preset value | | | LSB | MSB Dummy LSB | | F-Data | | | |

* Preset control: Bit 31: 1/O

Input data: Slave to host

| Octet 1 | Octet 2 | Octet 3 | Octet 4 | Octet 5 | Octet 6 | Octet 7 | Octet 8 | Octet 9 | Octet 10 |
|--------------------|---------|---------|---------|------------------|---------|---------|---------|---------|----------|
| MSB Position value | | | LSB | MSB Velocity LSB | | F-Data | | | |

Order code

Order code format encoder

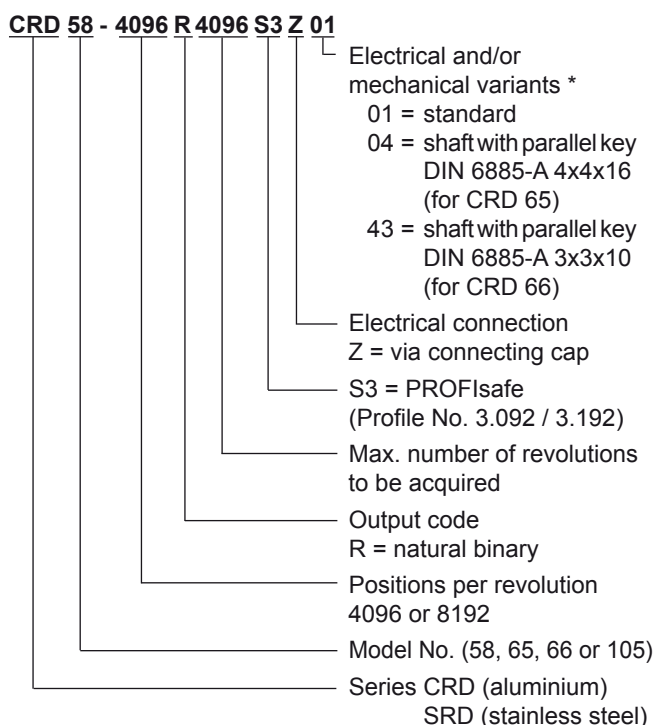

* The basic versions in accordance with the data sheet bear the code number 01. Variations from the basic version are indicated with a consecutive number and are documented in our works.

Order code format for connecting cap

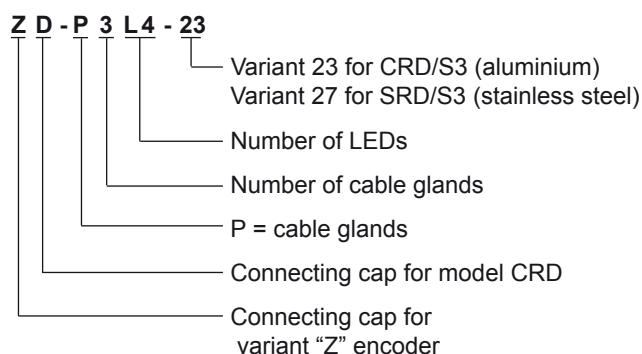

Note

For safety relevant applications we recommend a form-locked fixing for the shaft (parallel key). For this purpose the variants 04 and 43 are available.

Scope of delivery

- **STD25WS17** mating connector for the heating in design form 105.

Accessories (to be ordered separately)

- Installation accessories according to data sheet MZ 10111
- Backlash free clamp coupling KK14N, according to data sheets 12301
- Documentation on CD
 - TWK-CD-01** CD-ROM with documentation, device description file, bit map and example programme.

Documentation, GSD file, etc.

The following documents plus the GSD file, a bit map, the CRC calculation program and example programmes can be found in the Internet under www.twk.de in the documentation area, model CRD (letter "C")

- Data sheet No. CRD 12098
- Manual No. CRT 12099
- TÜV SIL2 certificate No. CRD 12464
- PNO PROFIsafe certificate No. CRD 12270
- PNO PROFIBUS certificate No. CRD 12271

A CD-ROM is also available on request.
(Please specify article No. TWK-CD-01 when ordering.)

Dimensions in mm

Model No. 58 with synchro-flange

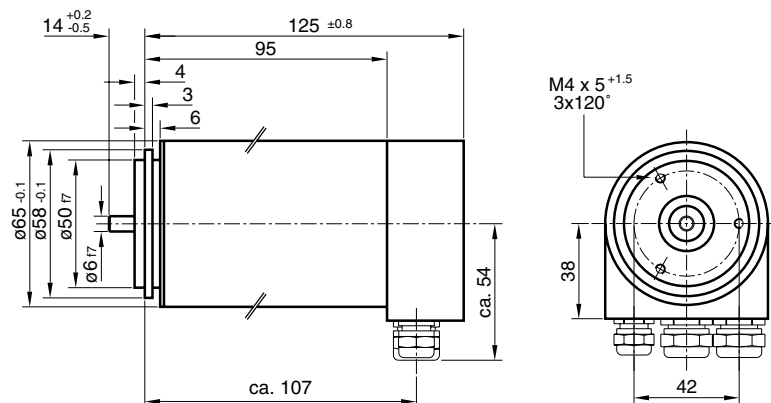

Model No. 65 with synchro-flange

- Option: Variant 04 with parallel key

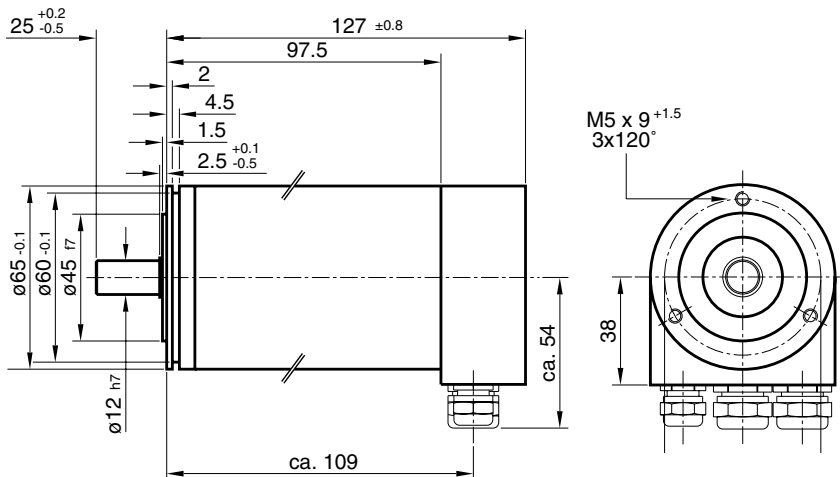
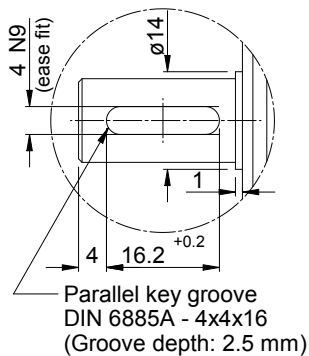

Model No. 66 with clamping flange and shaft with flat

- Option: Variant 43 with parallel key

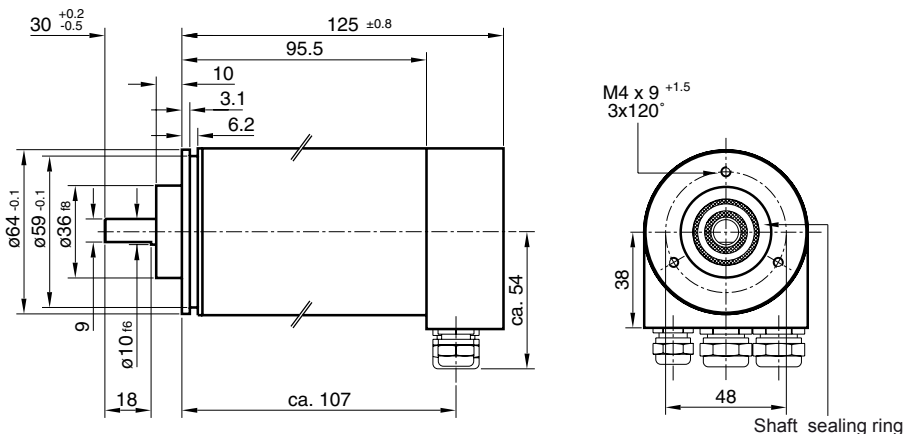
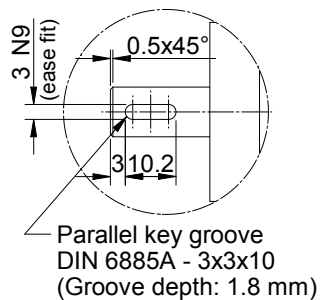

Dimensions in mm

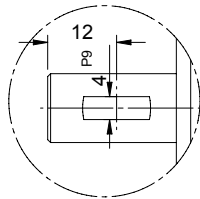
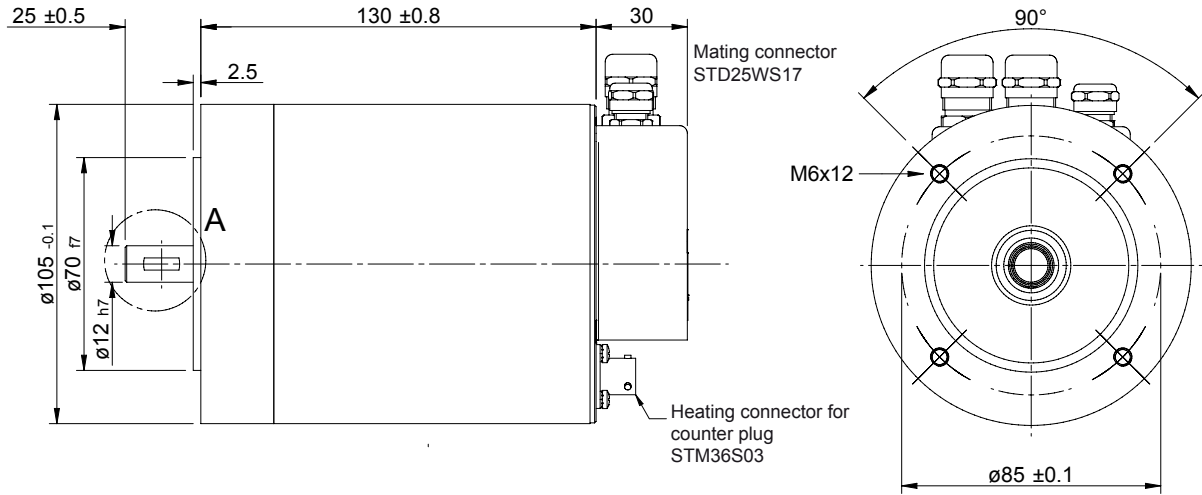

Detail A
2:1
Groove for woodruff key
4x 5 DIN 6888 Series A

Connection diagram heating connector

| Pin | Connection |
|-----|---|
| A | + V _S = +24 Volt ±10% I _o < 500 mA |
| B | - V _S = 0 Volt |
| C | n.c. |

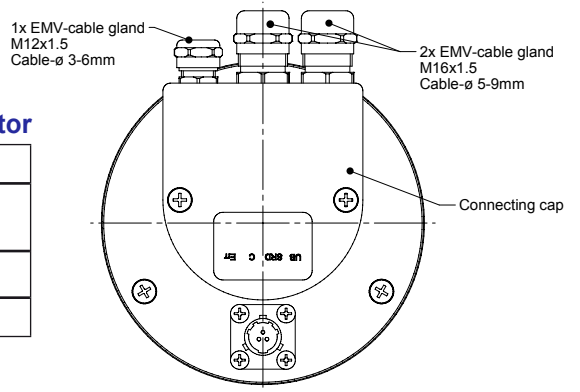

Connecting cap ZD-P3L4-23 (aluminium) / ZD-P3L4-27 (stainless steel)

The cap is listed as a separate item for ordering and delivery. The cap can be separated from the encoder for setting purposes by removing two screws.

