

MULTIBLOC / LS, LSES

Geared motors with worm & wheel, right angle output

IE2 drive systems
Variable speed and fixed speed
Power 0.25 to 9 kW
Torque 20 to 1500 Nm

MULTIBLOC /LS, LSES geared motors with worm & wheel, right angle output IE2 drive systems

Contents

General, Construction	3
Mounting - Operating positions	4 to 7
Selection.....	8 to 18
Method	8
List of applications.....	9
Adaptation possibilities, Designation / Coding.....	10
Conditions	11
Mb / AP - 4-pole	12
Mb 3101, AGMA Class I, II, III	13
Mb 2201, AGMA Class I, II, III	14
Mb 2301, AGMA Class I, II, III	15
Mb 2401, AGMA Class I, II, III	16
Mb 2501, AGMA Class I, II, III	17
Mb 2601, AGMA Class I, II, III	18
Mb dimensions	19 to 44
Synthesis	19
Mb dimensions, hollow shaft	20 to 31
Mb 3101, universal mounting MUT	20-21
Mb 2201, universal mounting MUF	22
Mb 2201, universal mounting MUT	23
Mb 2301, universal mounting MUF	24
Mb 2301, universal mounting MUT	25
Mb 2401, universal mounting MUF	26
Mb 2401, universal mounting MUT	27
Mb 2501, universal mounting MUF	28
Mb 2501, universal mounting MUT	29
Mb 2601, universal mounting MUF	30
Mb 2601, universal mounting MUT	31
Mb dimensions, output shaft.....	32 to 43
Mb 3101, universal mounting MUT	32-33
Mb 2201, universal mounting MUF	34
Mb 2201, universal mounting MUT	35
Mb 2301, universal mounting MUF	36
Mb 2301, universal mounting MUT	37
Mb 2401, universal mounting MUF	38
Mb 2401, universal mounting MUT	39
Mb 2501, universal mounting MUF	40
Mb 2501, universal mounting MUT	41
Mb 2601, universal mounting MUF	42
Mb 2601, universal mounting MUT	43
Dimensions of torque arm	44

MULTIBLOC /LS, LSES geared motors with worm & wheel, right angle output IE2 drive systems

General information



Multibloc geared motors with worm and wheel gears are used to adapt the speed of the electric motor to that of the driven machine.

Their size is therefore determined by the motor power (P) expressed in kilowatts (kW) and the output rotation speed of the gear box (n_S) in revolutions per minute (min^{-1}). The main characteristic of the speed reducers is the rated output torque (M_{nS}) expressed in Newton-metres (N.m) :

$$M_{nS} = \frac{P \times 9550}{n_S} \times \text{efficiency}$$

A range of six sizes: 31, 22, 23, 24, 25, 26.
 Rated output torque: from 20 N.m to 1500 N.m.
 Power rating: from 0.18 to 9 kW.
 Reduction ratios: from 5.2 to 100.
 Efficiency: 55 % to 88 %.
 Silent operation.

Construction

Description of Multibloc (Mb) gearboxes

Component	Materials	Remarks
Housing	Cast iron	- use of FGL cast iron (flake graphite: 150 MPa on breaking -Mb 31, 22, 23- and tensile strength 200 MPa -Mb 24, 25, 26-) single component perlite to ensure the complete sealing of the unit - monobloc with reinforced internal ribbing to absorb vibrations and noise and to increase rigidity - with NU housing, it becomes general by the adaptation of: <ul style="list-style-type: none"> • R torque arm kit, • S baseplate (Mb 31 excepted), • BS, BD or BN flanges. They are compact and meet industrial application related requirements.
Wheel	Bronze	- moulded around steel or cast iron inserts, blocked with respect to the worm, supported by two large diameter bearings without intermediate shields (excepting Mb 26)
Worm	Steel	- cut on whirl lathe, tempered and ground
Shafts	Steel	- grinding of the sealing surfaces - hollow cylindrical or output with key in accordance with ISO R773 - diameter tolerance h6 for output shaft and H7 for hollow shaft - tapped holes at output shaft end in accordance with DIN 332 form DR for mounting connecting equipment
Seals	Nitrile	- anti-dust lipseals according to DIN 3760 form AS - ground sealing surfaces
End shields	Cast iron	- on size 26, reinforced by large ribs, ensuring ruggedness of the gearbox under heavy loads
Lubrication	Oil	- in accordance with ISO 6743 / 6 - delivered with the quantity of oil corresponding to a multi-position operation, it is fitted with drain, level and vent plugs (excepting Mb 31)
Mounting		AP : input shaft gearbox (excepting Mb 31) MU (FT or FF) : geared motor with IEC motor, with universal mounting
Standard motor		LS, LSES: multi-voltage 230/400 VY - 400 VΔ - composite material (80 to 100) pressed steel (≥ 112) ventilation cover, on request fitted with a drip cover for operation in vertical position (shaft facing down) - LS: metal terminal box fitted with cable gland - LSES: terminal box made of composite material (80 to 112) aluminium alloy (≥ 132) equipped with threaded plugs (without cable glands) - IP 55 standard protection
Brake motors		FCR: failsafe brake asynchronous motor, ranging from 0.18 to 9 kW, IP 55 protection
Finish	Paint	Shade: RAL 6000 (green), system I (1 couche polyurethane vinyl layer of 25/30 μm)

MULTIBLOC /LS, LSES geared motors with worm & wheel, right angle output IE2 drive systems

Mounting - Operating positions

Standard position: gearbox seen from side F, motor to the rear, side D facing the ground.

1 - Mounting

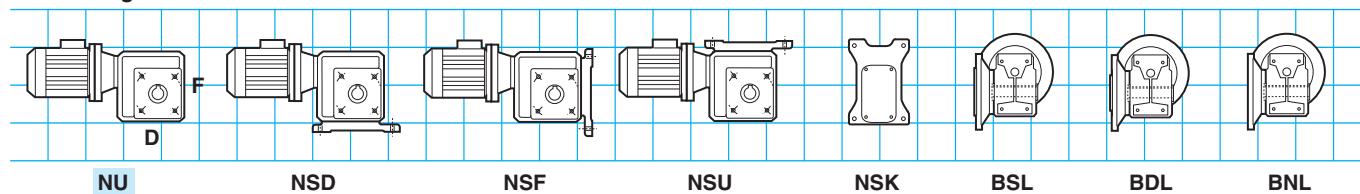

2 - Output shaft

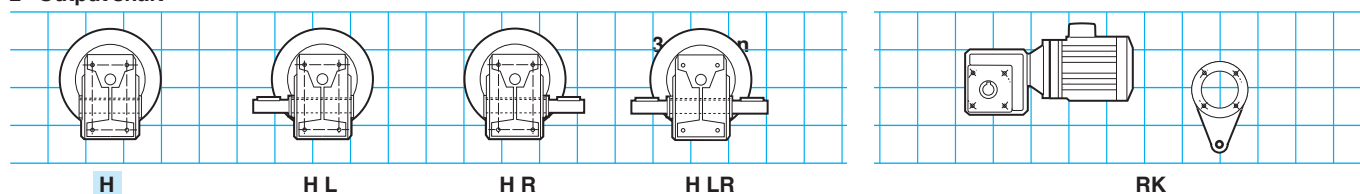

4 - Position

NU, NS, R mounting

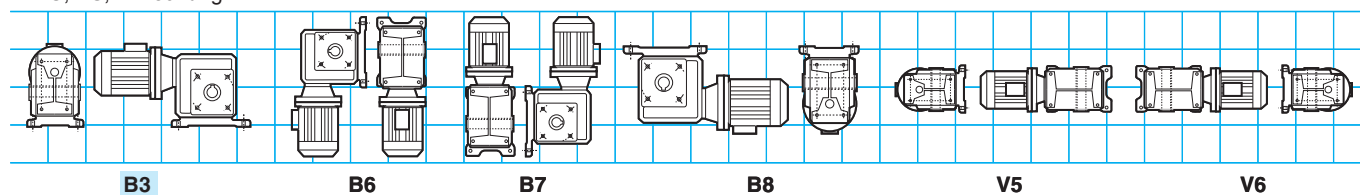

BS, BN, BD mounting

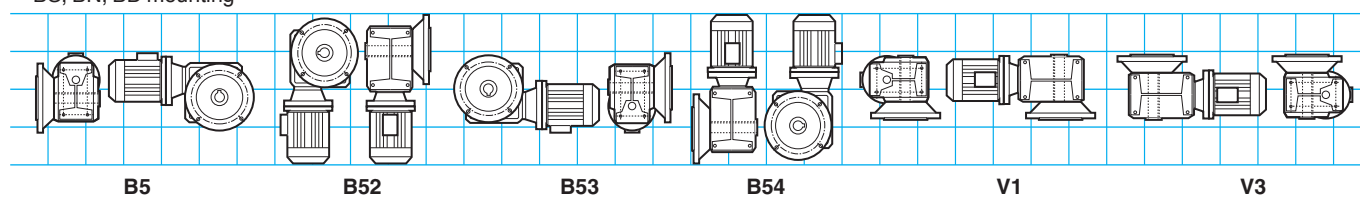

MULTIBLOC /LS, LSES geared motors with worm & wheel, right angle output IE2 drive systems

Mb NU, NS, R operating positions

The absolute orientation of the connection (TB : Up, Down, Right, Left, Front, Back) is related to the chosen operating position.

The relative orientation (0-90-180-270, in the trigonometric direction), a consequence of the absolute position, is related to the base of the gearbox (real or imaginary) for an observer, facing the gearbox.

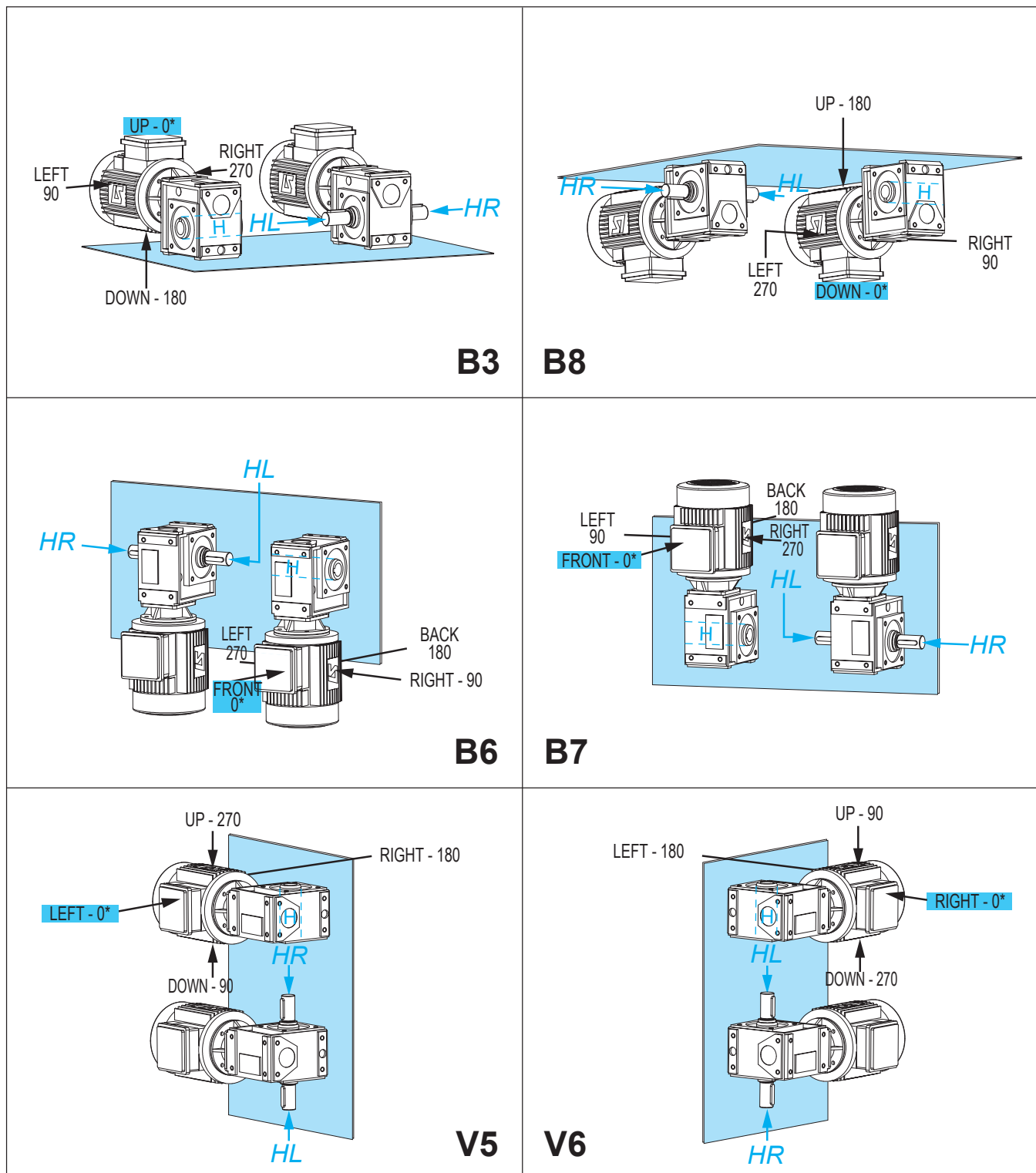

* Std terminal box

Output shaft on left HL, right HR, hollow H.

MULTIBLOC /LS, LSES geared motors with worm & wheel, right angle output IE2 drive systems

Mb BSL, BDL, BNL operating positions

The absolute orientation of the connection (TB : Up, Down, Right, Left, Front, Back) is related to the chosen operating position.

The relative orientation (0-90-180-270, in the trigonometric direction), a consequence of the absolute position, is related to the base of the gearbox (real or imaginary) for an observer, facing the gearbox.

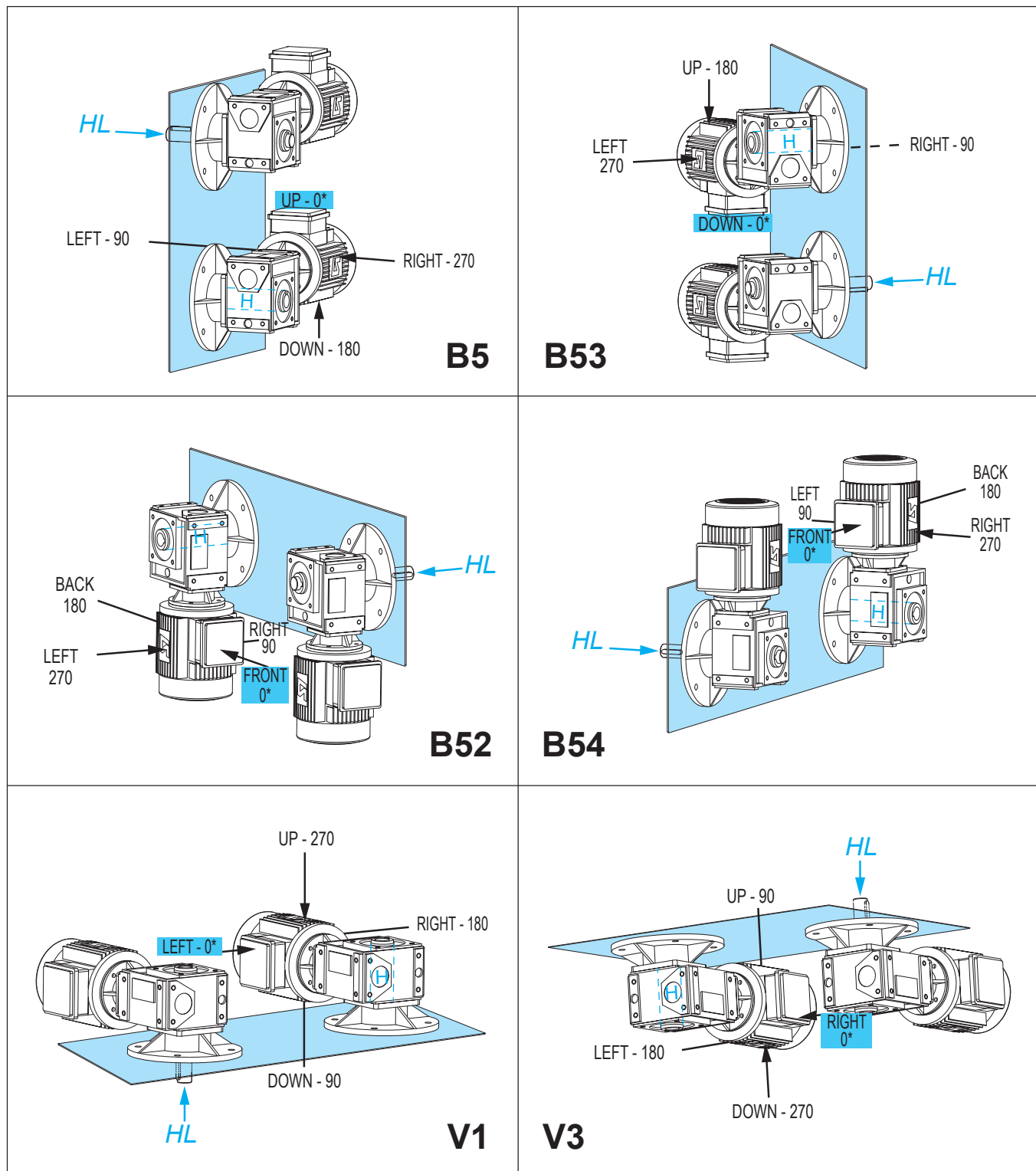

* Std terminal box

Output shaft on left HL, right HR, hollow H.

MULTIBLOC /LS, LSES geared motors with worm & wheel, right angle output IE2 drive systems

Mb BSR, BDR, BNR operating positions

The absolute orientation of the connection (TB : Up, Down, Right, Left, Front, Back) is related to the chosen operating position.

The relative orientation (0-90-180-270, in the trigonometric direction), a consequence of the absolute position, is related to the base of the gearbox (real or imaginary) for an observer, facing the gearbox.

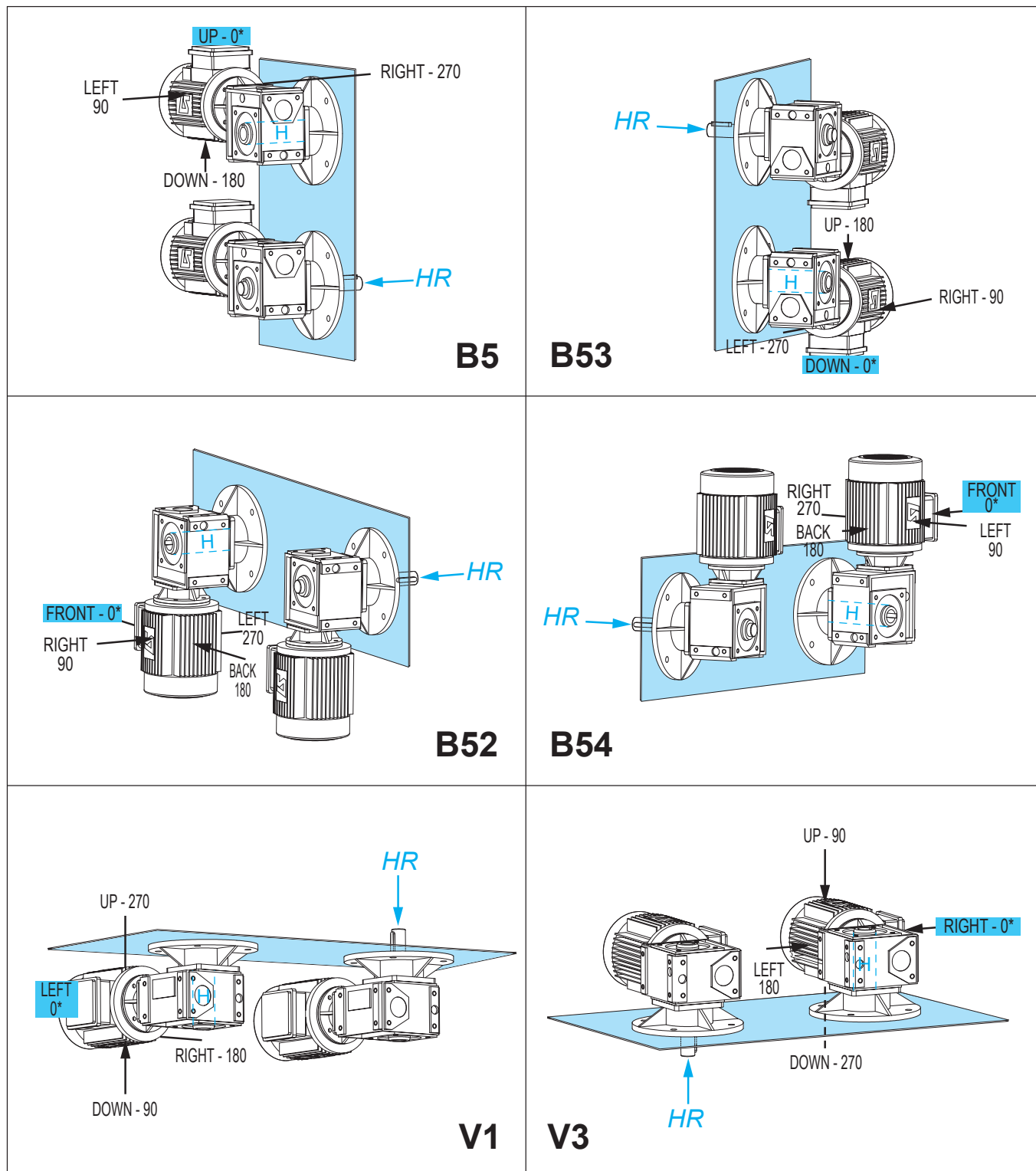

* Std terminal box

Output shaft on left HL, right HR, hollow H.

MULTIBLOC /LS, LSES geared motors with worm & wheel, right angle output IE2 drive systems

Selection

The selection of a gearbox or of a geared motor should take account of the application. Some of these applications are listed in the indicative "AGMA" load classification.

The opposite table summarises the relationship between the "AGMA" class and the gearbox duty factor K_p .

"AGMA" class	Gearbox duty factor K_p
I	1
II	1.4
III	2

NB: In the case of worm and wheel gearboxes such as Multibloc, the operating factor must be taken into account, that is the operating time at full load in relation to the total daily operating time of the gearbox.

In this catalogue, selection is made for an operating factor of 50 %.

For an operating factor of 100 %, class I becomes class II, and class II becomes class III. (K_p multiplied by 1.4)

1st case – Your application is listed

Follow the indicative "AGMA" load classification table, page 9 of this catalogue. ▼

Application example: Belt CONVEYOR

Operating time: 10 hours/day

"AGMA" class: I

Gearbox duty factor $K_p = 1$

Applications		OPERATION in hours / day		
		3h/day	10h/day	24h/day
CONVEYORS (loaded or fed uniformly)	belt	I	I	II
	chain	I	I	II

2nd case – Your application is not listed

The "AGMA" selection class is defined by the daily operating time and by the application operating type, according to the table below ▼

Type of application	Daily operating time	"AGMA" class
Shock-free, few starts	10 hours/day	I
Damped shocks	10 hours/day	II
Shock-free, few starts	24 hours/day	II
Violent shocks, many starts	10 hours/day	III
Damped shocks	24 hours/day	III

MULTIBLOC /LS, LSES geared motors with worm & wheel, right angle output IE2 drive systems

List of applications

OPERATION in hours/day				OPERATION in hours/day				OPERATION in hours/day			
	3 h/day	10 h/day	24 h/day		3 h/day	10 h/day	24 h/day		3 h/day	10 h/day	24 h/day
COOLING TOWERS	-	-	-	grinders (2 or more)	II	II	II*	bending rollers	II	II	II
AGITATORS				calenders	II	II	II*	nut tappers	II	III	III*
liquids with variable density	II	II	II	extruding machines	II	II	III	shears	III	III	III
liquids and solids	II	II	II	sheet forming machines	I	II	II*	MIXERS			
pure liquids	I	I	II	mixers	III	III	III*	constant density	I	I	II
semi-liquids, variable density	II	II	II*	CLARIFIERS	I	I	II	variable density	I	II	II
FOOD AND BEVERAGE INDUSTRY				SORTERS, GRADERS	I	II	II	cement, continuous duty	I	II	II
cereal cookers	I	I	II	COMPRESSORS	I	II	II	cement, intermittent duty	I	I	-
beet choppers	II	II	II	lobe	I	II	II	METALLURGY (industry)			
meat choppers	II	II	II	centrifugal	I	II	II	drawing frames, carriage	III	III	III*
dough mixers	I	II	II	CONVEYORS (loaded or fed uniformly)				drawing frames, main control	III	III	III*
extruding machines	I	II	III	belt		I	II	<i>table conveyor:</i>			
FEEDING (attachment)				chain	I	I	II	single direction of operation	I	II	III
reciprocating	III	III	III*	apron	I	I	II	reverse operation	III	III	III
disks	I	I	II	bucket	I	I	II	wire winders	I	II	II
lattice	I	II	II	scraper	I	I	II	sheet metal winders	I	II	II
belt	I	II	II	screw	I	I	II	spreading	III	III	III*
screw	I	II	II	assembly	I	I	II	roller drive			
TRANSMISSION SHAFT				furnace	I	I	II	splitting lines	II	II	III
loads with moderate shocks	I	II	II	CONVEYORS (loaded or fed non-uniformly)				wire drawing mills, flatteners	III	III	III*
loads with severe shocks	III	III	III*	<i>heavy duty:</i>				shape-cutting machines	III	III	III*
constant loads	I	I	II	belt	II	II	II	separating rollers	-	-	-
CLAY (industry)				chain	II	II	II	drying rollers	-	-	-
brick machines	III	III	III*	apron	II	II	II	PAPER (industry)			
processing machines	II	II	II	bucket	II	II	II	aerators	-	-	-
mixers	II	II	II	scraper	II	II	II	agitators, mixers	-	II	II
brick presses	III	III	III*	roller	I	I	II	wind up turrets	I	I	II
TIPPERS	III	III		screw	II	II	II	calenders	I	II	II*
TIMBER (industry)				reciprocating	III	III	III*	conveyors	I	II	II
<i>supplying:</i>				assembly	II	II	II	ball conveyors	III*	III*	III*
saws in series	III	III	III*	furnace	II	II	II	cutters, plating machines	I	II	II
shape-cutting machines	III	III	III*	vibratory	III	III	III*	bleaching vats	I	II	II
planers	II	II	III	removal	I	I	-	cylinders	I	II	II
cutting	II	II	III	CANE KNIVES	II	II	III	felt stitching machines	III*	III*	III*
chains	II	II	III	SIEVES				washers, thickeners	I	II	II*
turntable control	I	II	III	rotary	I	II	III	barking machines (mechanical)	III	III	III
main conveyors	I	II	III	stone washer with water circulation	I	I	II	pulp machines, uncoilers	I	II	II
ball conveyors	III	III	III*	DREDGERS				pulp hammers	II	II	II*
circular feed conveyors	I	II	III	shaker control	III	III	III*	presses	I	II*	II*
burner conveyors	I	II	III	cutting head control	III	III	III*	suction rollers	I	II	II*
waste conveyors	I	II	II	sieve control	III	III	III*	driers	I	II	II*
plank conveyors	III	III	III*	conveyors	I	II	II	wood pulp storing machines	I	II	II
transfer conveyors	I	II	III	pumps	I	II	II	barking drums	III	III	III*
<i>devices:</i>				cable winding drums	I	II	-	felt tension devices	I	II	II
for planer inclination	I	II	III	handling winches	II	II	-	PUMPS			
for ball turning	III	III	III*	service winches	II	II	-	<i>reciprocating:</i>			
barking machine, feeder	III	III	III*	CONTROL (vehicle)	II	II	II	multi-cylinder single-acting	I	II	II
main drive system barking machine	III	III	III*	ELEVATORS				centrifugal	I	I	II
roller drive system	III	III	III*	centrifugal unloading	I	I	II	dosing	I	II	II*
<i>haulage of balls:</i>				gravity unloading	I	I	II	<i>rotary:</i>			
inclined	III	III	III*	escalators	I	II	III	geared	I	I	II
well	III	III	III*	<i>buckets:</i>				lobed, vaned	I	I	II
<i>cross-cut saws:</i>				continuous load	I	I	II	SEWAGE PLANTS			
chain	II	II	III	heavy load	II	II	II	surface aerators	III	III	III
reciprocating	II	II	III	uniform load	I	I	II	duck type aerators	III	III	III
sorting tables	I	II	III	hoist for building materials	III	III	-	bar screens	I	I	II
ball support plates	III	III	III*	WINDING MACHINES	-	-	-	screw pumps	I	II	III
barking drums	III	III	III*	FILTERS	I	II	III	TEXTILES			
peeling tower	-	-	-	FURNACES				reelers (except drum)	I	II	II
<i>transfer:</i>				driers, coolers	I	II	II	calenders	I	II	II
on bogies	I	II	III	tumbling barrels	III	III	III*	padding calenders	I	II	II
chain	I	II	III	CRANES AND LIFTING				carding machines, spinners	I	II	II*
BREWERIES, DISTILLERIES				moving truck	-	-	-	alignment controls	-	-	-
boilers, continuous duty			II	moving bridge	-	-	-	glueing machines	I	II	II
cookers, continuous duty			II	bucket winches	-	-	-	drying machines, mangles	II	II	II
brewing vats, continuous duty			II	hoisting gear	-	-	-	napping mills	I	II	II
bottling machines	I	I	II	WINDLASSES, CAPSTANS	II	II	II*	washing machines	I	II	II
<i>scaling hoppers:</i>				PRINTING (presses)	I	I	II	soap milling machines	I	II	II
frequent starts	II	II	III	PACKAGING MACHINES				dyeing machines	I	II	II
GRINDERS				stackers	II	III	III	knitting machines	-	-	-
minerals	III	III	III*	wrapping machines	I	I	II	<i>cloth finishing machines:</i>			
stones	III	III	III*	WASHING MACHINES				washers, spreading machines	I	II	II
HAMMER MILLS	III	III	III*	drum	II	II	II	driers, calenders	I	II	II
ROTARY GRINDERS				reversible	II	II	II	thread preparation machines:			
rod mills	III	III	III*	MACHINE TOOLS				weaving looms	II	III	III
ball mills	III	III	III*	main drive system	I	II	II	spinning machines	I	I	II
pebble mills	III	III	III*	auxiliary drive system	I	I	II	driers	I	II	II
RUBBER (industry)				punching machines (geared)	III	III	III*	loading hoppers	II	II	II
air chamber extruder	II	II	II	flat planers	III	III	III*	VENTILATION	-	-	-

*: These classes assume minimum and normal conditions. To take account of variations which may affect the load conditions, it is recommended that applications are carefully researched before making a selection.

-: Consult Leroy-Somer

MULTIBLOC /LS, LSES geared motors with worm & wheel, right angle output IE2 drive systems

Adaptation possibilities

Leroy-Somer offers several drives for its gearboxes which meet a diverse range of needs. They are described below and offered in this catalogue in the section relating to gearboxes. For other drives, consult Leroy-Somer technical specialists who will be pleased to assist you.

Multibloc Mb gearboxes can be used in conjunction with the following drives:

- **3-phase asynchronous motors:**
 - LS motor from 0,18 to 9 kW
 - LSES motor from 0,75 to 9 kW
 - LS motor FCR brake from 0,18 to 9 kW
 - LSES motor FCR brake from 0,75 to 9 kW

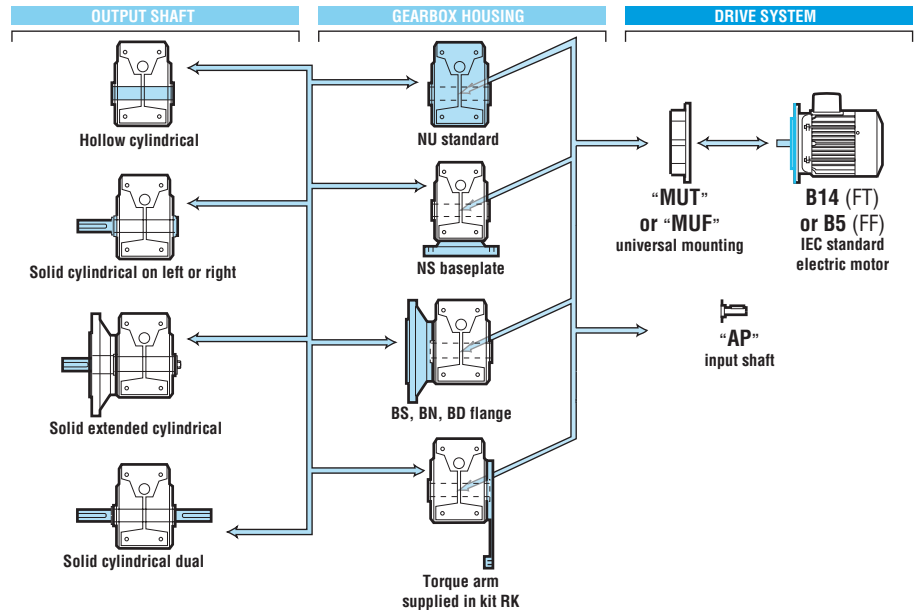

Designation / Coding

Mb	2301	20	NS	D	H	B3	MUT	4P	LSES 90 S	1.1 kW LS2/IE2	230/400 V 50 Hz	UG
Gearbox type	Size	Exact reduction	Mounting type	Mounting position	Output shaft definition	Operating position	Input type	No. of poles	Series, frame size, manufacturer index	Motor power, generation code and η classe	Voltage and mains frequency	Use

Codification example:

Multibloc Mb 2301 - 1.1 kW, 72 min⁻¹, class II

Designation: Mb 2301 - 20 NS D H B3 MUT
Code: 4749993
 4P LSES 90 S 1,1 kW LS2/IE2 230/400V 50 Hz UG

MULTIBLOC /LS, LSES geared motors with worm & wheel, right angle output IE2 drive systems

Conditions

Mb : NU, NS, BS, BD, BN, RK

4 pole - LS : IP55 - 50 Hz - Cl. F - 400 VY - from 0,25 to 0,55 kW - **LSES** : IP55 - 50 Hz - Cl. F - 400 VY, 400VΔ from 0,75 to 9 kW LS2/IE2 - U.G.

8 pole - LS : IP55 - 50 Hz - Cl. F - 400 VY - from 0,18 to 3 kW - U.G.

LS FCR brake : IP55 - 50 Hz - Cl. F - 400 V, LS from 0,18 to 9 kW - **LSES FCR brake** : from 0,75 to 9 kW - U.G.

Maximum quantity

Input MUT (b14) MUF (B5)	Mb 3101	Mb 2201	Mb 2301	Mb 2401	Mb 2501	Mb 2601
AP	-	-	-	-	-	-
LS	8p : 0,18 - 2,2 kW	-	5	5	5	5
	4p : 0,25 - 0,55 ¹ kW	5	5	5	5	-
LSES	4p : 0,75 - 9 kW	5	5	5	5	2
	8p : 0,18 - 2,2 kW	-	-	-	-	-
LS FCR	4p : 0,25 - 4 kW	5	5	5	5	2
	4p : 5,5 - 9 kW ²	-	-	-	-	2 ²
LSES FCR	4p : 0,75 - 9 kW	-	-	-	-	-

1. 0,55 kW for LS 71 except Mb 24 with LS 80

2. MUT (B14) only

Mechanical options and pages of dimensions corresponding to mounting and hollow shaft H

Type	Mb forms							
	NU	Baseplate	Flanges mounted			BTLR	Torque arm	Input shaft
		NS D/F/U	BSL / BSR	BDL / BDR	BNL / BNR		RK	AP
Mb 3101	21				20-21		44	
Mb 2201	23	22	23	22	22		44	22
Mb 2301	25	24	25	24	24		44	24
Mb 2401	27	26	27	26	26		44	26
Mb 2501	29	28	29	28	28		44	28
Mb 2601	31	30	31	30	30	31		30

Mechanical options and pages of dimensions corresponding to mounting and output shaft HL (left) HR (right)

Type	Mb forms					
	NU	Baseplate	Flanges mounted			Input shaft
		NS D/F/U	BSL / BSR	BDL / BDR	BNL / BNR	AP
Mb 3101	33				32-33	
Mb 2201	35	34	35	34	34	34
Mb 2301	37	36	37	36	36	36
Mb 2401	39	38	39	38	38	38
Mb 2501	41	40	41	40	40	40
Mb 2601	43	42	43	42	42	42

Options

Input 4p / MU	Electrical options			Mechanical options			Brake options		
	230/400V	400V Δ	PTO/CTP	Drip cover	Steel cover	DLRA	Different Mf	TRR	J01
LS	0,18 - 0,55 kW	-			-	-	-	-	-
	0,75 - 0,9 kW	-			-	-	-	-	-
LSES	1,1 - 3 kW				-	-	-	-	-
	4 - 9 kW				-	-	-	-	-
LS FCR	0,25 - 3 kW				-	-	-	-	-
	4 - 5,5 kW				-	-	-	-	-
LSES FCR	7,5 - 9 kW ¹				-	-	-	-	-
	0,75 - 9 kW ¹				-	-	-	-	-

1. MUT (B14) only for Mb 26

DG	<	2 WD	<	5 WD	<	10 WD	<	15 WD	<	To be agreed
----	---	------	---	------	---	-------	---	-------	---	--------------

DG : Availability ; n WD : Working Days

MULTIBLOC /LS, LSES geared motors with worm & wheel, right angle output IE2 drive systems

AP Selection

Mb «AP» - 1430 min⁻¹ - Kp = 1*

Rated capacities

n _s (min ⁻¹)	i	MULTIBLOC										
		3101**		2201		2301		2401		2501		2601
14.3	100		100	0.51	100	0.51	100	0.52	100	0.55	100	0.57
			0.3	102	0.5	170	0.71	247	1.24	455	2.21	841
17.9	80		80	0.55	80	0.55	80	0.57	80	0.6	80	0.62
			0.37	109	0.61	180	0.87	265	1.62	521	2.87	950
23.8	60		60	0.6	60	0.59	60	0.63	60	0.66	60	0.68
			0.41	99	0.7	164	1.01	256	1.84	486	3.32	905
28.6	50		50	0.61	50	0.64	50	0.66	50	0.69	50	0.72
			0.51	104	0.84	180	1.2	265	2.18	502	3.95	950
35.8	40		40	0.65	40	0.68	40	0.7	40	0.72	40	0.75
			0.6	104	1.02	186	1.47	275	2.69	518	4.89	980
47.7	30		30	0.71	30	0.7	30	0.74	30	0.76	30	0.8
			0.75	107	1.19	167	1.76	260	3.38	515	5.2	834
57.2	25.5		25.5	0.75	25.5	0.76	25.5	0.78	25.5	0.8	25.5	0.82
			0.77	99	1.28	166	1.86	247	3.51	478	6.55	915
71.5	20		20	0.79	20	0.79	19.5	0.8	20.5	0.82	20.5	0.83
			1.08	114	1.65	174	2.53	263	4.51	506	8.29	942
95.3	15		15	0.81	15	0.81	14.5	0.83	15.5	0.84	15.5	0.85
			1.34	109	1.87	152	3.08	247	5.66	492	10.71	942
124	11.5		11.5	0.84	11.5	0.84						
			1.71	110	2.77	179						
139	10.3		10.33	0.84	10.33	0.85	10.33	0.86	10.33	0.87	10.33	0.87
			1.75	102	2.83	166	4.29	255	8.51	511	15.15	909
196	7.3		7.33	0.86	7.5	0.88	7.25	0.88	7.25	0.88	7.5	0.88
			2.31	97	3.8	167	5.5	235	11.18	476	18.62	821
286	5.2				5.2	0.88						
					5.29	162						

*: check the duty factor of the application.

** : the Mb 3101 is designed with an integral input flange with tapped holes (FT85) which does not allow use of the «AP» version.

n_s : output speed

M_{ns} : rated output torque

Exact reduction	η
kW	M _{ns} (N.m)

MULTIBLOC /LS, LSES geared motors with worm & wheel, right angle output IE2 drive systems

Selection

Classes I, II, III (kp = 1, 1.4, 2)	Mb 31 LS IE1, LSES IE2, LSES brake, LS brake - IP 55 - Cl. F 230V/400V Y - 50 Hz - U.G.	Universal mounting MUT
--	--	----------------------------------

		Mb 3101				
		LS IM 3601-3611-3631 (B14-V18-V19) (kW)				
		0,25	0,37	0,55	0,75	0,9
		3-phase LS, LSES 4p				
		LS 71			LSES 80 ¹	
min	i exact					
14,3	100					
17,8	80	0,91				
23,8	60	1,15				
28,5	50	1,40	0,92			
35,6	40	1,94	1,28	0,84		
47,5	30	2,33	1,53	1,00		
57,0	25	2,16	1,42	0,93		
71,3	20	2,85	1,87	1,23	0,91	
95,0	15	3,85	2,53	1,65	1,22	1,01
114	12,5	4,31	2,83	1,85	1,37	1,14
143	10	5,26	3,45	2,26	1,67	1,39
187	7,5	6,52	4,28	2,80	2,07	1,72
LS, LSES 4p and brake		3-phase LS, LSES 4p				
LS FCR		71 L			80 L ¹	
LSES FCR		80 ¹				

1. LSES80 FT 85 ba 14 x 30 obligatory

Selection example

Required power: 0,55 kW

Required speed: 70 min⁻¹

Duty factor necessary for the application: Kp = 1

Operating position ; Mounting form: Horizontal B5; hollow shaft; flange

Designation : Mb 3101 i : 20 BNL H B5 - MUT 4p LS 71 L 0,55 kW - 400V Y - U.G.

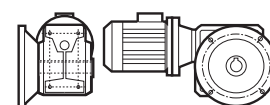

MULTIBLOC /LS, LSES geared motors with worm & wheel, right angle output IE2 drive systems

Selection AGMA I, II, III

Classes I, II, III (kp = 1, 1.4, 2)	Mb 2201	Universal mounting MUT
	LS IE1, LSES IE2, LS brake, LSES brake - IP 55 - Cl. F 230V/400V Y - 50 Hz - U.G.	Input shaft mounting AP

		Mb 2201									
		LS IM 3601-3611-3631 (B14-V18-V19) (kW)									
		0,18	0,25	0,37	0,55	0,75	0,9	1,1	1,5	1,8	
		3-phase LS, LSES 4p									
		71			80			90			
		3-phase LS 8p									
		80									
min-1	i exact										
7,00	100	1,19	0,83								
8,8	80	1,45	1,02								
11,7	60	1,68	1,18								
min-1	i exact										
14,2	100	1,35	0,87								
17,3	80	1,67	1,08								
23,7	60	1,89	1,22	0,79							
28,4	50	2,27	1,47	0,95							
35,5	40	2,69	1,74	1,13	0,83						
47,3	30	3,39	2,19	1,42	1,04	0,87					
55,7	25,5	3,45	2,23	1,44	1,06	0,88					
71,0	20	4,87	3,14	2,04	1,50	1,25	1,01				
94,7	15	6,05	3,91	2,54	1,87	1,56	1,26	0,91			
123	11,5	7,82	5,05	3,27	2,41	2,01	1,62	1,18	0,98		
137	10,3	7,87	5,08	3,30	2,42	2,02	1,63	1,19	0,99		
194	7,33		6,80	4,41	3,25	2,71	2,18	1,59	1,33		
		3-phase LS, LSES 4p									
LS, LSES 4p and brake		71 L			80 L			90 L			
LS FCR											
LSES FCR											
LS 8p and brake 3-phase LS 8p											
FCR		80									

The types of 8-poles motors are in bold italics.

Classes I, II, III (kp = 1, 1.4, 2)	Mb 2201	Universal mounting MUF
	LS IE1, LSES IE2, LS brake, LSES brake - IP 55 - Cl. F 230V/400V Y - 50 Hz - U.G.	Input shaft mounting AP

		Mb 2201									
		LS IM 3001-3011-3031 (B5-V1-V3) (kW)									
		0,18	0,25	0,37	0,55	0,75	0,9	1,1	1,5	1,8	
		3-phase LS, LSES 4p									
		LS 71			LSES 80			LSES 90 ¹			
		3-phase LS 8p									
		80									
min-1	i exact										
7,00	100	1,19	0,83								
8,8	80	1,45	1,02								
11,7	60	1,68	1,18								
min-1	i exact										
14,2	100	1,35	0,87								
17,3	80	1,67	1,08								
23,7	60	1,89	1,22	0,79							
28,4	50	2,27	1,47	0,95							
35,5	40	2,69	1,74	1,13	0,83						
47,3	30	3,39	2,19	1,42	1,04	0,87					
55,7	25,5	3,45	2,23	1,44	1,06	0,88					
71,0	20	4,87	3,14	2,04	1,50	1,25	1,01				
94,7	15	6,05	3,91	2,54	1,87	1,56	1,26	0,91			
123	11,5	7,82	5,05	3,27	2,41	2,01	1,62	1,18	0,98		
137	10,3	7,87	5,08	3,30	2,42	2,02	1,63	1,19	0,99		
194	7,33		6,80	4,41	3,25	2,71	2,18	1,59	1,33		
		3-phase LS, LSES 4p									
LS, LSES 4p and brake		71 L			80 L			90 L ¹			
LS FCR											
LSES FCR											
LS 8p and brake 3-phase LS 8p											
LS FCR		80									

The types of 8-poles motors are in bold italics.

1. LSES90 FF130 ba 19 x 40 obligatory

Selection example

Required power:	0,55 kW
Required speed:	35 min-1
Duty factor necessary for the application:	Kp = 1
Operating position ; Mounting form:	Horizontal B3 ; hollow shaft; baseplate
Designation:	Mb 2201 B3 NSD H i: 40 MUF - 4p LS 71 L 0.55 kW - 400V Y - U.G.

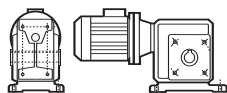

MULTIBLOC /LS, LSES geared motors with worm & wheel, right angle output IE2 drive systems

Selection AGMA I, II, III

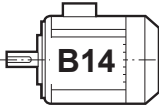
Classes I, II, III (kp = 1, 1.4, 2)		Mb 2301 LS IE1, LSES IE2, LS brake, LSES brake - IP 55 - Cl. F 230V/400V Y - 400V Δ - 50 Hz - U.G.										Universal mounting MUT Input shaft mounting AP					
		Mb 2301 LS IM 3601-3611-3631 (B14-V18-V19) (kW)															
		3-phase LS, LSES 4p															
		LS 71			LSES 80			LSES 90			LSES 100 ¹		LSES112 ²				
min-1 i exact		80		90													
7,00	100	2,01	1,39	0,90													
8,8	80	2,60	1,81	1,18													
11,7	60	2,94	2,04	1,33	0,87												
min-1 i exact																	
14,2	100	2,35	1,50	0,96													
17,8	80	2,67	1,70	1,10	0,80												
23,7	60	3,29	2,10	1,35	0,99	0,83											
28,4	50	3,95	2,52	1,62	1,19	0,99	0,80										
35,5	40	4,82	3,08	1,98	1,45	1,21	0,97										
47,3	30	5,71	3,64	2,34	1,72	1,43	1,15	0,84									
55,7	25,5	6,01	3,83	2,46	1,81	1,51	1,21	0,88									
71,0	20	7,90	5,04	3,24	2,38	1,98	1,59	1,16	0,97								
94,7	15	8,77	5,59	3,60	2,64	2,20	1,77	1,29	1,08	0,87							
123	11,5		8,39	5,39	3,96	3,30	2,65	1,93	1,61	1,30	0,95						
137	10,3		8,46	5,44	3,99	3,33	2,67	1,94	1,62	1,31	0,96						
189	7,5			7,47	5,48	4,57	3,67	2,67	2,23	1,80	1,31	0,99					
273	5,2				7,44	6,20	4,99	3,62	3,02	2,45	1,78	1,34					
LS, LSES 4p and brake		3-phase LS, LSES 4p															
LS FCR		71 L			80 L			90 L			100 L ¹		112 ²				
LSES FCR					80			90			100 ¹		112 ²				
LS 8p and brake		3-phase LS 8p															
LS FCR		80			90												

The types of 8-poles motors are in bold italics. 1. LSES100 FT 115 ba 24 x 50 obligatory. 2. LSES112 FT 115 ba 24 x 50 obligatory

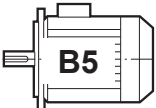
Classes I, II, III (kp = 1, 1.4, 2)		Mb 2301 LS IE1, LSES IE2, LS brake, LSES brake - IP 55 - Cl. F 230V/400V Y - 400V Δ - 50 Hz - U.G.										Universal mounting MUF Input shaft mounting AP					
		Mb 2301 LS IM 3001-3011-3031 (B5-V1-V3) (kW)															
		3-phase LS, LSES 4p															
		LS 71			LSES 80			LSES 90			LSES 100 ¹		LSES112 ²				
min-1 i exact		80		90													
7,00	100	2,01	1,39	0,90													
8,8	80	2,60	1,81	1,18													
11,7	60	2,94	2,04	1,33	0,87												
min-1 i exact																	
14,2	100	2,35	1,50	0,96													
17,8	80	2,67	1,70	1,10	0,80												
23,7	60	3,29	2,10	1,35	0,99	0,83											
28,4	50	3,95	2,52	1,62	1,19	0,99	0,80										
35,5	40	4,82	3,08	1,98	1,45	1,21	0,97										
47,3	30	5,71	3,64	2,34	1,72	1,43	1,15	0,84									
55,7	25,5	6,01	3,83	2,46	1,81	1,51	1,21	0,88									
71,0	20	7,90	5,04	3,24	2,38	1,98	1,59	1,16	0,97								
94,7	15	8,77	5,59	3,60	2,64	2,20	1,77	1,29	1,08	0,87							
123	11,5		8,39	5,39	3,96	3,30	2,65	1,93	1,61	1,30	0,95						
137	10,3		8,46	5,44	3,99	3,33	2,67	1,94	1,62	1,31	0,96						
189	7,5			7,47	5,48	4,57	3,67	2,67	2,23	1,80	1,31	0,99					
273	5,2				7,44	6,20	4,99	3,62	3,02	2,45	1,78	1,34					
LS, LSES 4p and brake		3-phase LS, LSES 4p															
LS FCR		71 L			80 L			90 L			100 L ¹		112 ²				
LSES FCR					80			90			100 ¹		112 ²				
LS 8p and brake		3-phase LS 8p															
LS FCR		80			90												

The types of 8-poles motors are in bold italics. 1. LSES100 FF 165 ba 24 x 50 obligatory. 2. LSES112 FF 165 ba 24 x 50 obligatory

Selection example

Required power: 1,1 kW
 Required speed: 70 min-1
 Duty factor necessary for the application: Kp = 1,4
 Operating position ; Mounting form: Horizontal B8 ; hollow shaft; flange
 Designation : Mb 2301 i : 20 NSD H B8 - MUT 4p LSES90S 1,1 kW LS2/IE2 - 400V Y - U.G.

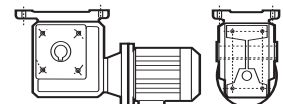

MULTIBLOC /LS, LSES geared motors with worm & wheel, right angle output IE2 drive systems

Selection AGMA I, II, III

Classes I, II, III (kp = 1, 1.4, 2)		Mb 2401 LS IE1, LSES IE2, LS brake, LSES brake - IP 55 - Cl. F 230V/400V Y - 400V Δ - 50 Hz - U.G.										Universal mounting MUT		
												Input shaft mounting AP		
Mb 2401														
LS IM 3601-3611-3631 (B14-V18-V19) (kW)														
		3-phase LS, LSES 4p												
		LS 80 ¹			LSES80			LSES90			LSES100		LSES112	LSES132 ²
3-phase LS 8p														
min-1 i exact		80			90			100						
6,85 100		2,96 2,04 1,32 0,86												
8,6 80		3,57 2,46 1,59 1,03												
11,4 60		4,29 2,96 1,91 1,24			0,90									
min-1 i exact														
14,4 100					1,38 1,01 0,84									
17,9 80					1,70 1,24 1,03 0,83									
23,8 60					1,97 1,44 1,20 0,96									
28,6 50					2,35 1,71 1,43 1,14			0,83						
36,0 40					2,88 2,10 1,75 1,41			1,02 0,85						
47,9 30					3,46 2,52 2,10 1,69			1,22 1,02			0,82			
56,3 25,5					3,65 2,66 2,22 1,78			1,29 1,08			0,87			
73,6 19,5					3,59 2,99 2,40 1,74			1,45 1,17 0,85						
99,1 14,5					4,40 3,67 2,94 2,13			1,78 1,44 1,05 0,79						
139 10,3					6,12 5,10 4,09 2,96			2,47 2,00 1,45 1,09			0,79			
198 7,25					7,95 6,63 5,31 3,85			3,21 2,59 1,89 1,42			1,03			
LS, LSES 4p and brake														
3-phase LS, LSES 4p														
LS FCR		80 L			90 L			100 L			112	132 ²		
LSES FCR		80			90			100			112	132 ²		
LS 8p and brake														
LS FCR														
		80			90			100						

The types of 8-poles motors are in bold italics. 1. 0,55 kW for LS 80 (FT 100 ba 19 x 40). 2. LSES132 FT130 ba 28 x 60 obligatory.

Classes I, II, III (kp = 1, 1.4, 2)		Mb 2401 LS IE1, LSES IE2, LS brake, LSES brake - IP 55 - Cl. F 230V/400V Y - 400V Δ - 50 Hz - U.G.										Universal mounting MUT		
												Input shaft mounting AP		
Mb 2401														
LS IM 3001-3011-3031 (B5-V1-V3) (kW)														
		3-phase LS, LSES 4p												
		LS 71			LSES80			LSES90			LSES100		LSES112	LSES132 ¹
3-phase LS 8p														
min-1 i exact		80			90			100						
7,00 100		2,96 2,04 1,32 0,86												
8,8 80		3,57 2,46 1,59 1,03												
11,7 60		4,29 2,96 1,91 1,24			0,90									
min-1 i exact														
14,4 100		3,43 2,16 1,38 1,01 0,84												
17,9 80		4,24 2,67 1,70 1,24 1,03 0,83												
23,8 60		4,91 3,09 1,97 1,44 1,20 0,96												
28,6 50		5,84 3,67 2,35 1,71 1,43 1,14			0,83									
36,0 40		7,17 4,52 2,88 2,10 1,75 1,41			1,02 0,85									
47,9 30		8,60 5,42 3,46 2,52 2,10 1,69			1,22 1,02			0,82						
56,3 25,5		9,08 5,37 3,65 2,66 2,22 1,78			1,29 1,08			0,87						
73,6 19,5					3,59 2,99 2,40 1,74			1,45 1,17 0,85						
99,1 14,5					4,40 3,67 2,94 2,13			1,78 1,44 1,05 0,79						
139 10,3					6,12 5,10 4,09 2,96			2,47 2,00 1,45 1,09			0,79			
198 7,25					7,95 6,63 5,31 3,85			3,21 2,59 1,89 1,42			1,03			
LS, LSES 4p and brake														
3-phase LS, LSES 4p														
LS FCR		71 L			80 L			90 L			100 L	112	132 ¹	
LSES FCR		80			90			100			112	132 ¹		
LS 8p and brake														
LS FCR														
		80			90			100						

The types of 8-poles motors are in bold italics. 1. LSES132 FF 165 ba 28 x 60 obligatory.

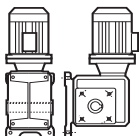

Selection example

Required power: 1,1 kW
 Required speed: 73 min-1
 Duty factor necessary for the application: Kp = 2
 Operating position ; Mounting form: B7 ; hollow shaft; baseplate
Designation : Mb 2401 i : 19,5 NSD H B7 - MUT 4p LSES90S 1,1 kW LS2/IE2 - 400V Y - U.G.

MULTIBLOC /LS, LSES geared motors with worm & wheel, right angle output IE2 drive systems

Selection AGMA I, II, III

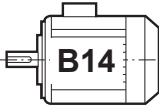
Classes I, II, III (kp = 1, 1.4, 2)		Mb 2501 LS IE1, LSES IE2, LS brake, LSES brake - IP 55 - Cl. F 230V/400V Y - 400V Δ - 50 Hz - U.G.										Universal mounting MUT	
												Input shaft mounting AP	
		Mb 2501 LS IM 3601-3611-3631 (B14-V18-V19) (kW)											
		3-phase LS, LSES 4p											
		LS 71		LSES80		LSES90		LSES100		LSES112		LSES132 ¹	
		3-phase LS 8p											
min-1	i exact	90		100		100		112					
7,00	100	2,34	1,51	1,09									
8,8	80	3,05	1,97	1,42		0,96							
11,7	60	3,60	2,32	1,68		1,13	0,85						
min-1	i exact			1,80		1,50		1,19		0,86			
14,4	100			2,38		1,98		1,58		1,14		0,95	
18,0	80			2,73		2,28		1,81		1,31		1,09	
24,0	60			3,24		2,70		2,15		1,55		1,29	
28,8	50			3,99		3,33		2,64		1,91		1,59	
36,0	40			4,98		4,15		3,30		2,39		1,99	
47,9	30			5,59		4,66		3,71		2,68		2,23	
56,4	25,5			6,60		5,50		4,38		3,16		2,63	
70,2	20,5							5,48		3,96		3,30	
92,8	15,5							8,21		5,93		4,94	
139	10,3							7,80		6,50		5,24	
198	7,25											3,81	
		3-phase LS, LSES 4p											
LS FCR				80		90		100		112		132 ¹	
LSES FCR				80		90		100		112		132 ¹	
LS 8p and brake		3-phase LS 8p											
LS FCR		90		100		100		112					

The types of 8-poles motors are in bold italics. 1. LSES132 FT 130 ba 28 x 60 obligatory

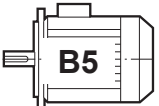
Classes I, II, III (kp = 1, 1.4, 2)		Mb 2501 LS IE1, LSES IE2, LS brake, LSES brake - IP 55 - Cl. F 230V/400V Y - 400V Δ - 50 Hz - U.G.										Universal mounting MUT	
												Input shaft mounting AP	
		Mb 2501 LS IM 3001-3011-3031 (B5-V1-V3) (kW)											
		3-phase LS, LSES 4p											
		LS 71		LSES80		LSES90		LSES100		LSES112		LSES132 ¹	
		3-phase LS 8p											
min-1	i exact	90		100		100		112					
7,00	100	2,34	1,51	1,09									
8,8	80	3,05	1,97	1,42		0,96							
11,7	60	3,60	2,32	1,68		1,13	0,85						
min-1	i exact			1,80		1,50		1,19		0,86			
14,4	100			2,38		1,98		1,58		1,14		0,95	
18,0	80			2,73		2,28		1,81		1,31		1,09	
24,0	60			3,24		2,70		2,15		1,55		1,29	
28,8	50			3,99		3,33		2,64		1,91		1,59	
36,0	40			4,98		4,15		3,30		2,39		1,99	
47,9	30			5,59		4,66		3,71		2,68		2,23	
56,4	25,5			6,60		5,50		4,38		3,16		2,63	
70,2	20,5							5,48		3,96		3,30	
92,8	15,5							8,21		5,93		4,94	
139	10,3							7,80		6,50		5,24	
198	7,25											3,81	
		3-phase LS, LSES 4p											
LS FCR				80		90		100		112		132 ¹	
LSES FCR				80		90		100		112		132 ¹	
LS 8p and brake		3-phase LS 8p											
LSFCR		90		100		100		112					

The types of 8-poles motors are in bold italics. 1. LSES132 FF 165 ba 28 x 60 obligatory

Selection example

Required power: 3 kW
 Required speed: 47,5 min-1
 Duty factor necessary for the application: Kp = 1
 Operating position ; Mounting form: Horizontal B3 ; shaft on the left
Designation : Mb 2501 B3 NU HL i : 30 MUT - 4p LSES100LR 3 kW LS2/IE2 - 400V Y - U.G.

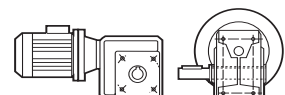

MULTIBLOC /LS, LSES geared motors with worm & wheel, right angle output IE2 drive systems

Selection AGMA I, II, III

Classes I, II, III (kp = 1, 1.4, 2)	Mb 2601	Universal mounting MUT
	LS IE1, LSES IE2, LS brake, LSES brake - IP 55 - Cl. F 230V/400V Y - 400V Δ - 50 Hz - U.G.	Input shaft mounting AP

		Mb 2601												
		LS IM 3601-3611-3631 (B14-V18-V19) (kW)												
		0,37	0,55	0,75	0,9	1,1	1,5	1,8	2,2	3	4	5,5	7,5	9
		3-phase LS, LSES 4p												
		LS 71	LSES80		LSES90		LSES100 ¹		LSES112 ¹		LSES132			
		3-phase LS 8p												
min-1	i exact	<i>100¹</i>		<i>100¹</i>		<i>112¹</i>		<i>132</i>						
7,00	100			1,96		1,32	1,00							
8,8	80			2,55		1,71	1,29		0,98					
11,7	60			2,91		1,95	1,48		1,00					
min-1	i exact													
14,4	100								1,04					
18,0	80								1,34	0,98				
23,9	60								1,58	1,15	0,86			
28,7	50								1,91	1,39	1,04			
36,0	40								2,37	1,72	1,29	0,93		
47,9	30								2,51	1,82	1,37	0,99		
56,4	25,5								3,16	2,29	1,72	1,24	0,91	
70,2	20,5								3,97	2,88	2,16	1,56	1,14	0,95
92,8	15,5								5,14	3,73	2,8	2,02	1,48	1,23
139	10,3								7,21	5,23	3,92	2,83	2,08	1,73
192	7,5								8,75	6,35	4,76	3,44	2,52	2,1
		3-phase LS, LSES 4p												
		LS FCR		100 ¹		112 ¹		132						
		LSES FCR		100 ¹		112 ¹		132						
		LS 8p and brake 3-phase LS 8p												
		FCR		100 ¹		100 ¹		112 ¹		132				

LS, LSES 4p and brake 3-phase LS, LSES 4p
 The types of 8-poles motors are in bold italics. 1. LSES100 and 112 FT215 ba 38 x 80 obligatory

Classes I, II, III (kp = 1, 1.4, 2)	Mb 2601	Universal mounting MUF
	LS IE1, LSES IE2, LS brake, LSES brake - IP 55 - Cl. F 230V/400V Y - 400V Δ - 50 Hz - U.G.	Input shaft mounting AP

		Mb 2601												
		LS IM 3001-3011-3031 (B5-V1-V3) (kW)												
		0,37	0,55	0,75	0,9	1,1	1,5	1,8	2,2	3	4	5,5	7,5	9
		3-phase LS, LSES 4p												
		LS 71	LSES80		LSES90		LSES100		LSES112		LSES132 ¹			
		3-phase LS 8p												
min-1	i exact	<i>90</i>		<i>100</i>		<i>100</i>		<i>112</i>		<i>132¹</i>				
7,00	100	4,26	2,72	1,96		1,32	1,00							
8,8	80	5,54	3,54	2,55		1,71	1,29		0,98					
11,7	60	6,32	4,04	2,91		1,95	1,48		1,00					
min-1	i exact													
14,4	100					2,16	1,56	1,30	1,04					
18,0	80					2,79	2,01	1,68	1,34	0,98				
23,9	60					3,29	2,37	1,98	1,58	1,15	0,86			
28,7	50					3,97	2,85	2,38	1,91	1,39	1,04			
36,0	40					4,93	3,54	2,95	2,37	1,72	1,29	0,93		
47,9	30					5,21	3,75	3,13	2,51	1,82	1,37	0,99		
56,4	25,5					6,56	4,72	3,93	3,16	2,29	1,72	1,24	0,91	
70,2	20,5					8,25	5,93	4,94	3,97	2,88	2,16	1,56	1,14	0,95
92,8	15,5						7,69	6,41	5,14	3,73	2,8	2,02	1,48	1,23
139	10,3							8,98	7,21	5,23	3,92	2,83	2,08	1,73
192	7,5								8,75	6,35	4,76	3,44	2,52	2,1
		3-phase LS, LSES 4p												
		LS FCR		90		100		112		132 ¹				
		LSES FCR		90		100		112		132 ¹				
		LS 8p and brake 3-phase LS 8p												
		FCR		90		100		112		132 ¹				

LS, LSES 4p and brake 3-phase LS, LSES 4p
 The types of 8-poles motors are in bold italics. 1. LSES132 FF 165 ba 28 x 60 obligatory

Selection example



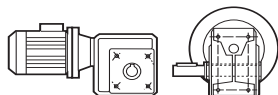

Required power:	7,5 kW
Required speed:	70 min-1
Duty factor necessary for the application:	Kp = 1
Operating position ; Mounting form:	Horizontal B3 ; shaft on the left
Designation :	Mb 2601 i : 20,5 NU HL B3 - MUF 4p LSES132M 7,5 kW LS2/IE2 - 400V Y - U.G.

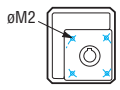

MULTIBLOC /LS, LSES geared motors with worm & wheel, right angle output IE2 drive systems

Synthesis

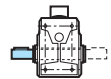
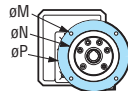
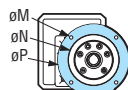
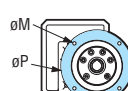
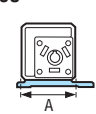
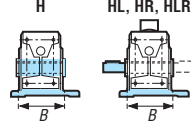
Dimensions in mm

Mountings	Shaft	MULTIBLOC							
		Mb 31	Mb 22	Mb 23	Mb 24	Mb 25	Mb 26		
 øM2	 H	Ø 20H7 x 90	Ø 25H7 x 108	Ø 30H7 x 118	Ø 35H7 x 138	Ø 45H7 x 168	Ø 50H7 x 188		
		M2 = 85	M2 = 105	M2 = 115	M2 = 130	M2 = 180	-		
	HL HR HLR	Ø 20h6 x 40	Ø 25h6 x 50	Ø 30h6 x 60	Ø 35h6 x 70	Ø 45h6 x 90	Ø 50h6 x 100		
		M2 = 85	M2 = 105	M2 = 115	M2 = 130	M2 = 180	-		
 øM øN øP	H HL, HR, HLR	H	-	M = 165	M = 165	M = 215	M = 265	M = 300	
		HL	-	N = 130	N = 130	N = 180	N = 230	N = 250	
		HR	-	P = 200	P = 200	P = 250	P = 300	P = 350	
		HLR	-						
 øM øN øP	H HL, HR, HLR	H	-	M = 130	M = 130	M = 165	M = 215	M = 265	
		HL	-	N = 110	N = 110	N = 130	N = 180	N = 230	
		HR	-	P = 160	P = 160	P = 200	P = 250	P = 300	
		HLR	-						
 øM øP	H HL, HR, HLR	H	M = 100/85/115	M = 165	M = 165	M = 215	M = 265	M = 300	
		HL	P = 120/105/140	N = 200	N = 200	N = 250	N = 300	N = 350	
		HR							
		HLR							
Feet NSD, NSF, NSU  A	H HL, HR, HLR  B	H	-	A = 134	A = 154	A = 202	A = 220	A = 250	
		HL	-	B = 125	B = 128	B = 156	B = 156	B = 180	
		HR							
		HLR							
MU/LS, LSES  MU-FT B14 IEC Std  MU-FF B5 IEC Std	Frame size	71	FT85-14x30	FT85-14x30	FT85-14x30	-	-	-	
		80	FT85-14x30	FT85-14x30	FT85-14x30	-	-	-	
		80	-	FT100-19x40	FT100-19x40	FT100-19x40	FT100-19x40	FT100-19x40	-
		80	-	-	FT115-24x50	FT115-24x50	FT115-24x50	FT115-24x50	-
		90	-	FT100-19x40	FT100-19x40	FT100-19x40	FT100-19x40	FT100-19x40	-
		90	-	-	FT115-24x50	FT115-24x50	FT115-24x50	FT115-24x50	-
		90	-	-	-	FT130-28x60	FT130-28x60	FT130-28x60	-
		100	-	-	FT115-24x50	FT115-24x50	FT115-24x50	FT115-24x50	-
		100	-	-	-	FT130-28x60	FT130-28x60	FT130-28x60	-
		100	-	-	-	-	-	-	FT215-38x80
		112	-	-	FT115-24x50	FT115-24x50	FT115-24x50	FT115-24x50	-
		112	-	-	-	FT130-28x60	FT130-28x60	FT130-28x60	-
		112	-	-	-	-	-	-	FT215-38x80
		132	-	-	-	FT130-28x60	FT130-28x60	FT130-28x60	-
		132	-	-	-	-	-	-	FT215-38x80
		71	-	FF130-14x30	FF130-14x30	FF130-14x30	-	-	-
		80	-	FF130-14x30	FF130-14x30	FF130-14x30	-	-	-
		80	-	FF165-19x40	FF165-19x40	FF165-19x40	FF165-19x40	FF165-19x40	-
		80	-	-	FF165-19x40	FF165-19x40	-	-	-
		90	-	FF165-19x40	FF165-19x40	FF165-19x40	FF165-19x40	FF165-19x40	-
		90	-	FF130-19x40	FF165-24x50	FF165-24x50	FF165-24x50	FF165-24x50	FF165-24x50
		90	-	-	-	FF215-28x60	FF215-28x60	FF215-28x60	FF215-28x60
		100	-	-	FF165-24x50	FF165-24x50	FF165-24x50	FF165-24x50	FF165-24x50
		100	-	-	-	FF215-28x60	FF215-28x60	FF215-28x60	FF215-28x60
112	-	-	FF165-24x50	FF165-24x50	FF165-24x50	FF165-24x50	FF165-24x50		
112	-	-	-	FF215-28x60	FF215-28x60	FF215-28x60	FF215-28x60		
132	-	-	-	FF165-28x60	FF165-28x60	FF165-28x60	FF165-28x60		
132	-	-	-	FF215-28x60	FF215-28x60	FF215-28x60	FF215-28x60		

MULTIBLOC /LS, LSES geared motors with worm & wheel, right angle output IE2 drive systems

Dimensions

Dimensions of Multibloc (Mb) geared motors, MU universal mounting, Mb 3101

Dimensions in millimetres

- BN1 L* flange on left, H hollow shaft

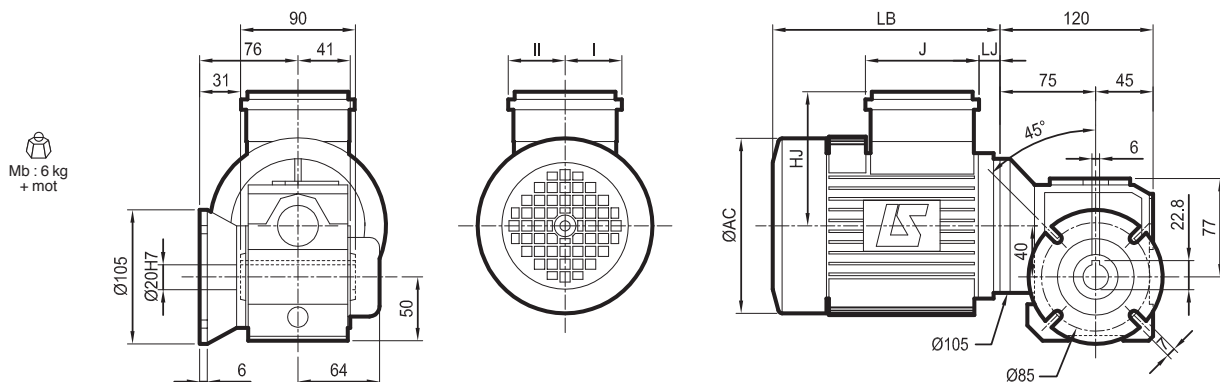

* option on right BN1 R H : identical flange and shaft

- BN2 L* flange on left, H hollow shaft

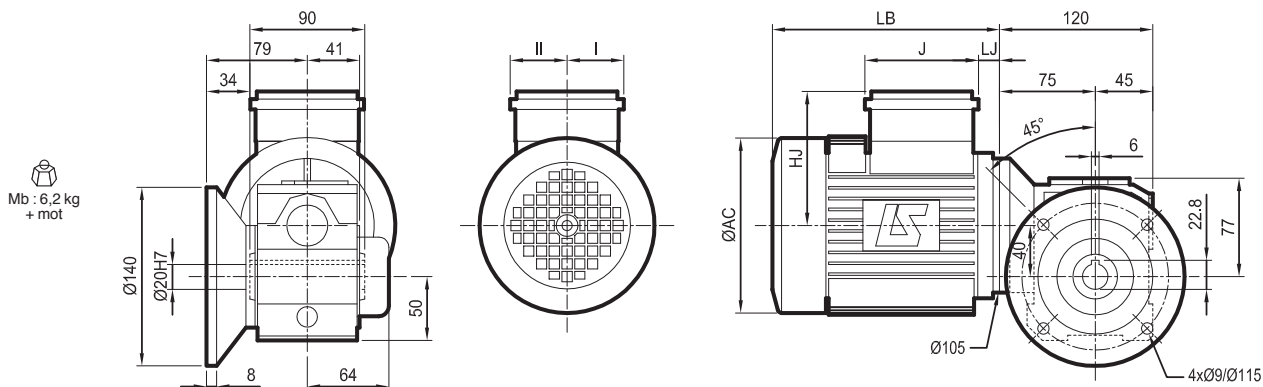

* option on right BN2 R H : identical flange and shaft

- Driven shaft details

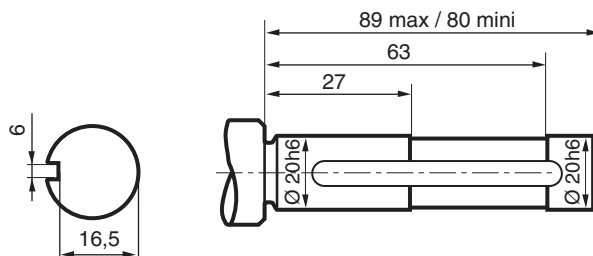

MULTIBLOC /LS, LSES geared motors with worm & wheel, right angle output IE2 drive systems

Dimensions

Dimensions of Multibloc (Mb) geared motors, MU universal mounting, Mb 3101 MUT LS

Dimensions in millimetres

- NU standard, H hollow shaft

Mb : 5 kg + mot

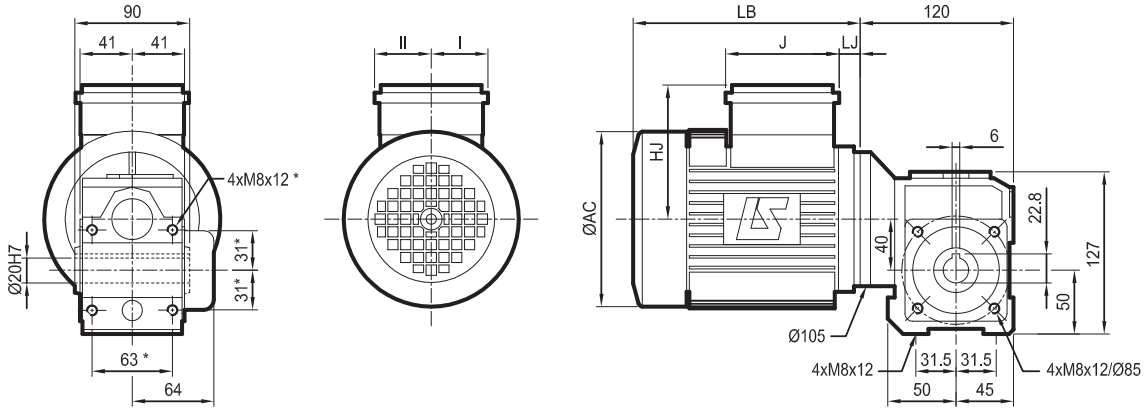

* option NUF on request

- BN L* flange on left, H* hollow shaft

Mb : 6 kg + mot

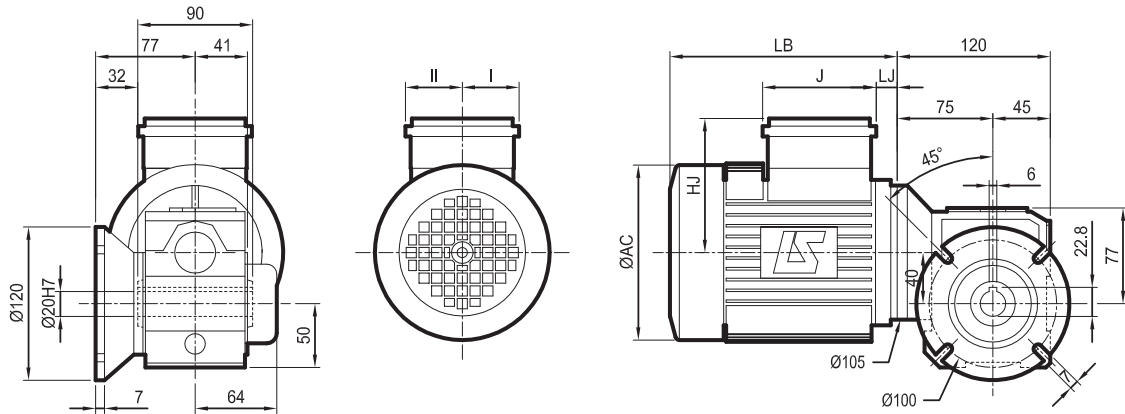

* option on right BNR H: identical flange and shaft

Type	4 poles motors										kg	4 poles motors										kg
	LSES MUT					LSES FCR MUT						LSES FCR MUT										
	AC	HJ	J	LB	LJ	PU	RU	I	II		AC	HJ	J	LB	LJ	PU	RU	I	II			
LS80	171	135	86	267	67,5	105	0	43	43	11,7	172	146	160	304	13	105	0	55	55	18		

Type	4, 8 poles motors										kg	4, 8 poles motors										kg
	LS MUT					LS FCR MUT						LS FCR MUT										
	AC	HJ	J	LB	LJ	PU	RU	I	II		AC	HJ	J	LB	LJ	PU	RU	I	II			
LS71 L	140	99	86	193	26	105	0	43	43	8,3	140	135	160	245	13	105	0	55	55	11		
LS80 L	-	-	-	-	-	-	-	-	-	-	172	146	160	300	46	105	0	55	55	18		

Std CEI

MULTIBLOC /LS, LSES geared motors with worm & wheel, right angle output IE2 drive systems

Dimensions

Dimensions of Multibloc (Mb) geared motors, MU universal mounting, Mb 2201 MUT LS

Dimensions in millimetres

- NU standard, H hollow shaft

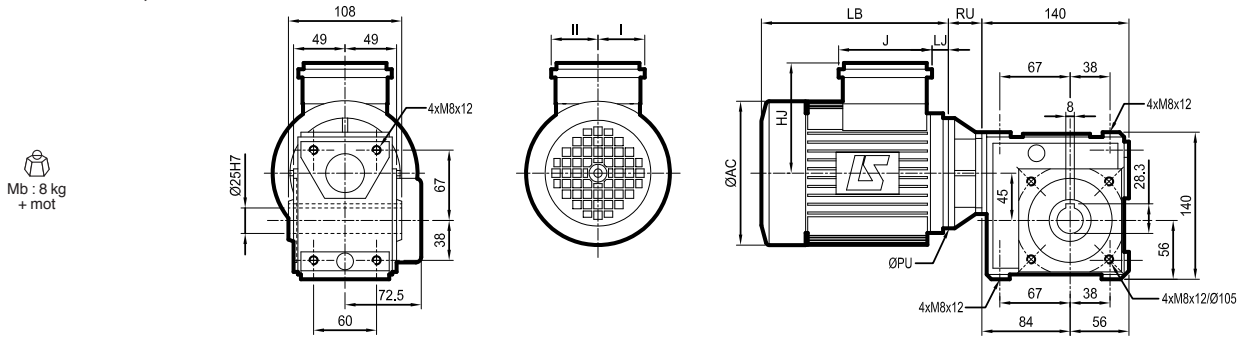

- BS¹ L* flange on left, H* hollow shaft

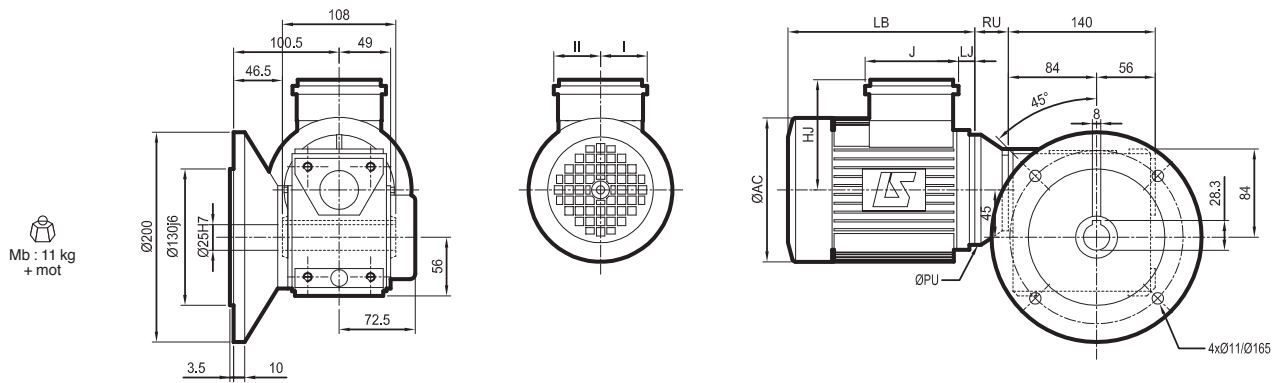

1. or BN flange: details page 22
* option on right BSR H: identical flange and shaft

Type	4 poles motors										kg	4 poles motors										kg
	LSES MUT					kg	LSES FCR MUT					kg										
	AC	HJ	J	LB	LJ		PU	RU	I	II			AC	HJ	J	LB	LJ	PU	RU	I	II	
LSES 80	183	135	86	267	26	120	33	43	43	12,7	184	156	160	304	13	120	33	55	55	25,2		
LSES 90	189	135	86	245	26	120	33	43	43	15,6	184	156	160	304	13	120	33	55	55	25,2		

Type	4, 8 poles motors										kg	4, 8 poles motors										kg
	LS 71 - 4 pole ; LS 80 - 8 pole MUT					kg	LS FCR MUT					kg										
	AC	HJ	J	LB	LJ		PU	RU	I	II			AC	HJ	J	LB	LJ	PU	RU	I	II	
LS 71 L	140	99	86	193	26	105	31	43	43	9	140	135	160	245	13	105	31	55	55	12		
LS 80 L	170	123	86	215	26	120	33	43	43	11,5	172	146	160	265	13	120	33	55	55	19,2		
LS 90 L	-	-	-	-	-	-	-	-	-	-	184	156	160	304	13	120	33	55	55	25,2		

Std CEI

MULTIBLOC /LS, LSES geared motors with worm & wheel, right angle output IE2 drive systems

Dimensions

Dimensions of Multibloc (Mb) geared motors, MU universal mounting, Mb 2301 MUT LS

Dimensions in millimetres

- NU standard, H hollow shaft

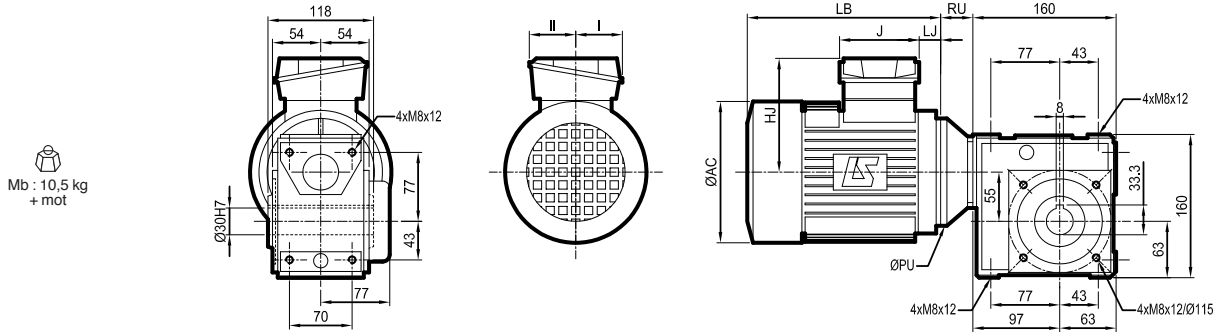

Mb : 10,5 kg
+ mot

- BS¹ L* flange on left, H* hollow shaft

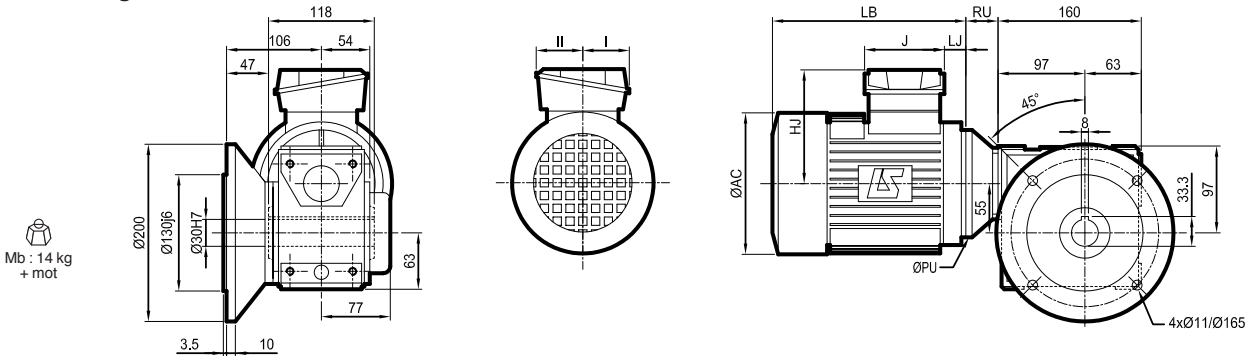

Mb : 14 kg
+ mot

1. or BN flange: details page 24
* option on right BSR H: identical flange and shaft

Type	4 poles motors										kg									
	LSES MUT					LSES FCR MUT														
	AC	HJ	J	LB	LJ	PU	RU	I	II	kg										
LSES 80	183	135	86	267	26	120	36	43	43	12,7	190	156	160	304	13	120	36	55	55	25,2
LSES 90	190	135	86	245	26	140	38	43	43	16,7	190	156	160	304	13	140	38	55	55	25,2
LSES 100	235	140	86	309	27	140	35	43	43	26,7	200	161	160	364,5	21	140	35	55	55	31
LSES 112	235	149	86	333	35,5	140	38	43	43	36	235	169	160	396	23,5	140	38	55	55	42

Type	4, 8 poles motors										kg									
	LS 71 - 4 poles ; LS 80 and 90 - 8 poles MUT					LS FCR MUT														
	AC	HJ	J	LB	LJ	PU	RU	I	II	kg										
LS 71 L	140	99	86	193	26	105	35	43	43	9,2	140	135	160	245	13	105	35	55	55	12
LS 80 L	170	123	86	215	26	120	36	43	60	12	172	146	160	265	13	120	36	55	55	19,2
LS 90 L	190	133	86	245	26	140	36	43	60	16	190	156	160	304	13	140	38	55	55	25,2
LS 100 L	-	-	-	-	-	-	-	-	-	-	200	161	160	351	21	140	35	55	55	31
LS 112	-	-	-	-	-	-	-	-	-	-	235	169	160	396	23,5	140	38	55	55	42

Std CEI

MULTIBLOC /LS, LSES geared motors with worm & wheel, right angle output IE2 drive systems

Dimensions

Dimensions of Multibloc (Mb) geared motors, MU universal mounting, Mb 2401 MUT LS

Dimensions in millimetres

- NU standard, H hollow shaft

Mb : 17,5 kg + mot

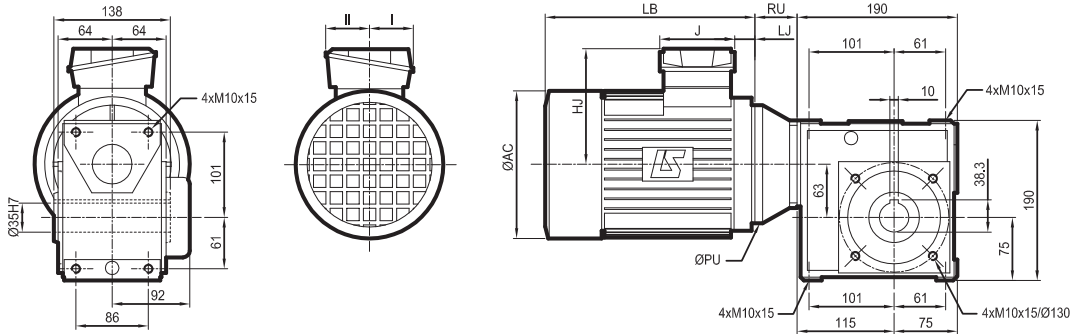

- BS¹ L* flange on left, H* hollow shaft

Mb : 23 kg + mot

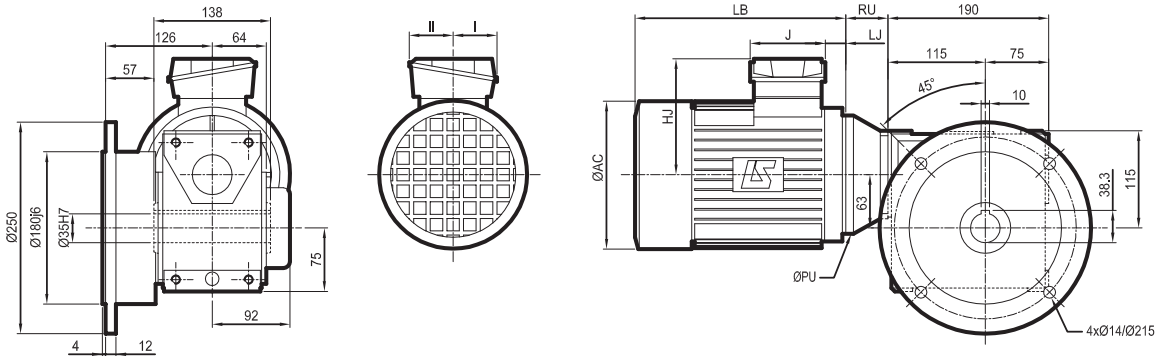

1. or BN flange: details page 26
* option on right BSR H: identical flange and shaft

Type	4 poles motors										kg									
	LSES MUT					LSES FCR MUT														
	AC	HJ	J	LB	LJ	PU	RU	I	II	AC		HJ	J	LB	LJ	PU	RU	I	II	
LSES 80	183	135	86	267	26	120	50	43	43	13,5	184	156	160	304	13	120	50	55	55	26
LSES 90	190	135	86	245	26	140	50	43	43	16,4	184	156	160	304	13	140	50	55	55	26
LSES 100	235	140	86	309	27	160	50	43	43	27,5	200	161	160	364,5	21	160	50	55	55	31,8
LSES 112	235	149	86	333	35,5	160	50	43	43	36,8	235	169	160	396	23	160	50	55	55	42,8
LSES 132	220	172	126	377	32	160	50	63	63	43,8	235	169	160	457	41	160	50	55	55	43,8

Type	4, 8 poles motors										kg									
	LS 8 pole MUT					LS FCR MUT														
	AC	HJ	J	LB	LJ	PU	RU	I	II	AC		HJ	J	LB	LJ	PU	RU	I	II	
LS 80 L	170	123	86	215	26	120	50	43	60	12,7	172	146	160	265	13	120	50	55	55	20
LS 90 L	190	133	86	245	26	140	50	43	60	17	184	156	160	304	13	140	50	55	55	26
LS 100 L	200	138	86	290	26	160	50	43	60	24,3	200	161	160	351	21	160	50	55	55	31,8
LS 112	-	-	-	-	-	-	-	-	-	-	235	169	160	396	23	160	50	55	55	42,8
LS 132 S	-	-	-	-	-	-	-	-	-	-	235	169	160	437	41	160	50	55	55	43,8

Std CEI

MULTIBLOC /LS, LSES geared motors with worm & wheel, right angle output IE2 drive systems

Dimensions

Dimensions of Multibloc (Mb) geared motors, MU universal mounting, Mb 2501 MUF LS

Dimensions in millimetres

- BDL* flange on left, H hollow shaft

Mb : 37 kg + mot

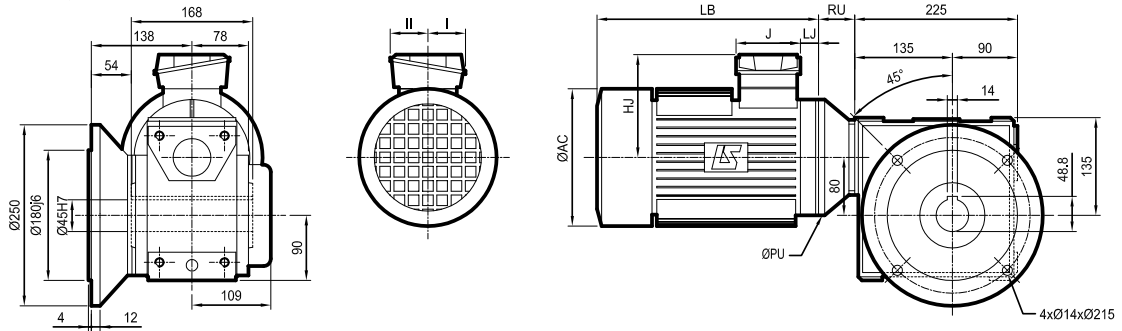

* option on right BDR H: identical flange and shaft

- NSD* baseplate, H hollow shaft

Mb : 34 kg + mot

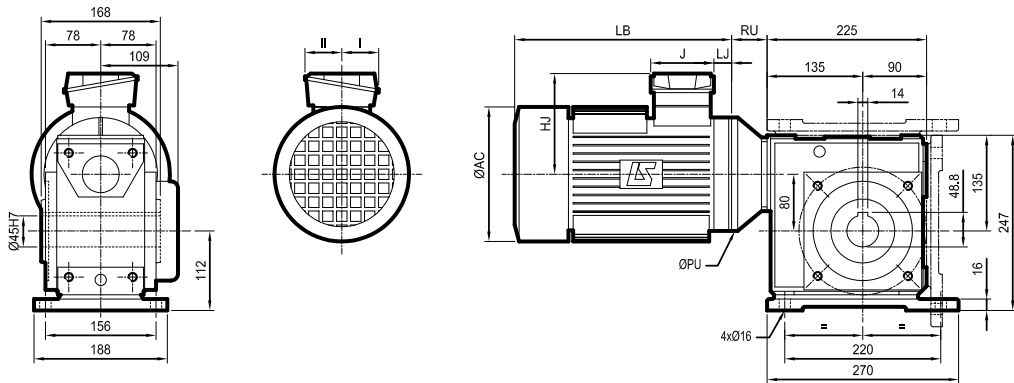

* NSF or NSU baseplate

- Flange details BN L

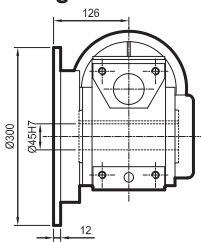

driven shaft

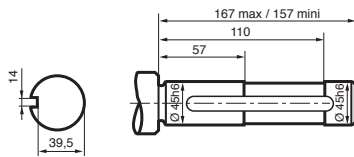

Details AP

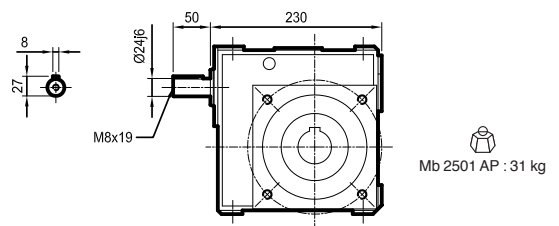

Type	4 poles motors										kg	4 poles motors										kg								
	LSES MUF					LSES FCR MUF						LSES MUF					LSES FCR MUF													
	AC	HJ	J	LB	LJ	PU	RU	I	II		AC	HJ	J	LB	LJ	PU	RU	I	II		AC	HJ	J	LB	LJ	PU	RU	I	II	
LS 80	183	135	86	247	26	200	50	43	43	14,7	184	156	160	324	38	200	50	55	55	27,2	184	156	160	324	33	200	50	55	55	27,2
LS 90	190	135	86	265	46	200	50	43	43	17,6	184	156	160	324	33	200	50	55	55	27,2	200	161	160	400,5	50	250	50	55	55	33
LS 100	235	140	86	309	27	250	50	43	43	28,7	235	169	160	425	49	250	50	55	55	44	200	161	160	388	50	250	50	55	55	33
LS 112	235	149	86	333	35,5	250	50	43	43	38	235	169	160	425	49	250	50	55	55	44	235	169	160	425	49	250	50	55	55	44
LS 132	265	190	126	412	17	250	50	63	63	71	280	188	160	533	65	250	50	55	55	78	280	188	160	533	65	250	50	55	55	78

Type	4, 8 poles motors										kg	4, 8 poles motors										kg								
	LS 8 pole MUF					LS 8 pole MUF						LS FCR MUF					LS FCR MUF													
	AC	HJ	J	LB	LJ	PU	RU	I	II		AC	HJ	J	LB	LJ	PU	RU	I	II		AC	HJ	J	LB	LJ	PU	RU	I	II	
LS 80 L	-	-	-	-	-	-	-	-	-	-	172	146	160	292	38	200	50	55	55	21,2	184	156	160	324	33	200	50	55	55	27,2
LS 90 L	190	133	86	265	46	200	50	43	60	18,4	184	156	160	324	33	200	50	55	55	27,2	200	161	160	388	50	250	50	55	55	33
LS 100 L	200	138	86	290	26	250	50	43	60	25,6	200	161	160	388	50	250	50	55	55	33	235	169	160	425	49	250	50	55	55	44
LS 112	200	138	86	290	26	250	50	43	60	27,9	235	169	160	425	49	250	50	55	55	44	280	188	160	533	65	250	50	55	55	78
LS 132	-	-	-	-	-	-	-	-	-	-	280	188	160	533	65	250	50	55	55	78	280	188	160	533	65	250	50	55	55	78

Std CEI

MULTIBLOC /LS, LSES geared motors with worm & wheel, right angle output IE2 drive systems

Dimensions

Dimensions of Multibloc (Mb) geared motors, MU universal mounting, Mb 2501 MUT LS

Dimensions in millimetres

- NU standard, H hollow shaft

Mb : 31 kg + mot

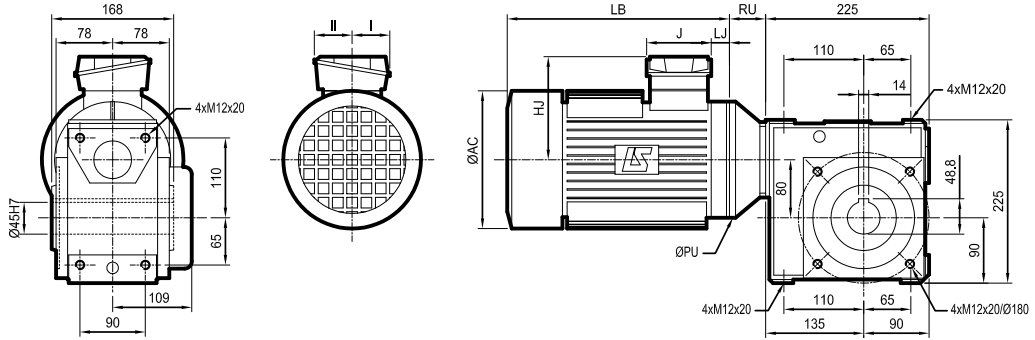

- BS¹ L* flange on left, H* hollow shaft

Mb : 38 kg + mot

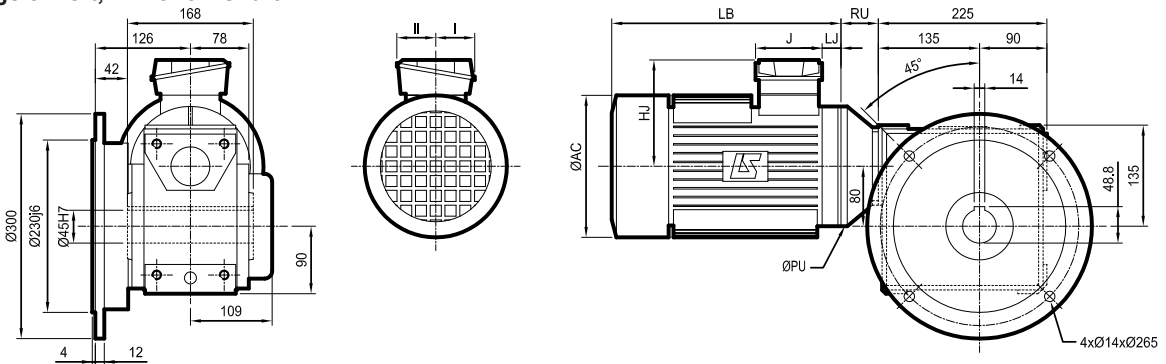

1. or BN flange: details page 28
* option on right BSR H: identical flange and shaft

4 poles motors

Type	LSES MUT										kg	LSES FCR MUT										kg
	AC	HJ	J	LB	LJ	PU	RU	I	II			AC	HJ	J	LB	LJ	PU	RU	I	II		
LSES 80	183	135	86	247	26	120	50	43	43	13,5	190	156	160	304	13	120	50	55	55	26		
LSES 90	190	135	86	245	26	140	50	43	43	16,4	190	156	160	304	13	140	50	55	55	26		
LSES 100	235	140	86	309	27	160	50	43	43	27,5	200	161	160	363,5	21	160	50	55	55	31,8		
LSES 112	235	149	86	333	35,5	160	50	43	43	36,8	235	169	160	396	23	160	50	55	55	42,8		
LSES 132	265	190	126	412	17	160	50	43	43	69,8	280	188	160	493	25	160	50	55	55	76,8		

4, 8 poles motors

Type	LS 8 pole MUT										kg	LS FCR MUT										kg
	AC	HJ	J	LB	LJ	PU	RU	I	II			AC	HJ	J	LB	LJ	PU	RU	I	II		
LS 80 L	-	-	-	-	-	-	-	-	-	-	172	146	160	265	13	120	50	55	55	20		
LS 90 L	190	133	86	245	26	140	50	43	60	17	184	156	160	304	13	140	50	55	55	26		
LS 100 L	200	138	86	290	26	160	50	43	60	24,3	200	161	160	351	21	160	50	55	55	31,8		
LS 112	200	138	86	290	26	160	50	43	60	26,7	235	169	160	396	23	160	50	55	55	42,8		
LS 132	-	-	-	-	-	-	-	-	-	-	280	188	160	493	25	160	50	55	55	76,8		

Std CEI

MULTIBLOC /LS, LSES geared motors with worm & wheel, right angle output IE2 drive systems

Dimensions

Dimensions of Multibloc (Mb) geared motors, MU universal mounting, Mb 2601 MUF LS

Dimensions in millimetres

- BDL* flange on left, H hollow shaft

Mb : 56 kg
+ mot

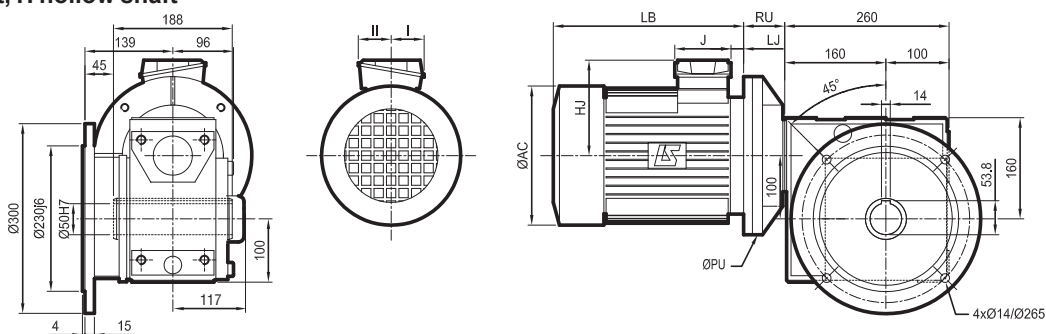

* option on right BDR H: identical flange and shaft

- NSD* baseplate, H hollow shaft

Mb : 44 kg
+ mot

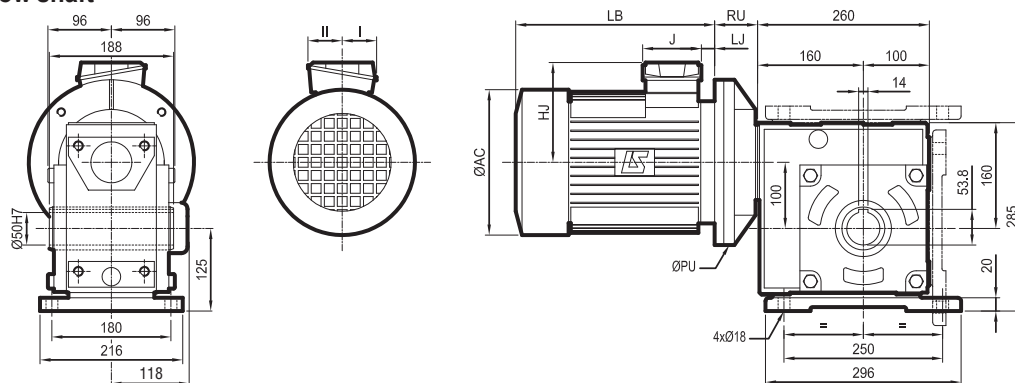

* NSF or NSU baseplate

- Flange details BN L

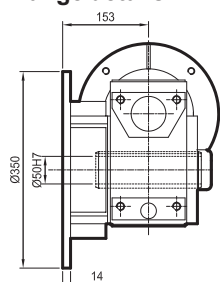

driven shaft

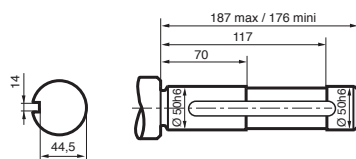

Details AP

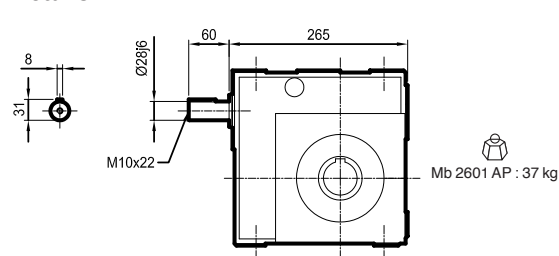

Type	4 poles motors										kg
	LSES MUF					LSES FCR MUF					
	AC	HJ	J	LB	LJ	PU	RU	I	II		kg
LSES 90	190	135	86	265	46	200	59	43	43	18,2	27,8
LSES 100	235	140	86	309	27	250	51	43	43	29,3	33,6
LSES 112	235	149	86	333	35,5	250	51	43	43	38	44,6
LSES 132	265	190	126	452	57	250	51	63	63	71	78,6

Type	4, 8 poles motors										kg
	LS 8 pole MUF					LS FCR MUF					
	AC	HJ	J	LB	LJ	PU	RU	I	II		kg
LS 90 L	190	133	86	265	46	200	59	43	60	18,8	27,8
LS 100 L	200	138	86	290	26	250	51	43	60	26	33,6
LS 112	200	138	86	290	26	250	51	43	60	28,5	44,6
LS 132	280	175	110	387	25	250	51	57	73	63,5	78,6

Std CEI

MULTIBLOC /LS, LSES geared motors with worm & wheel, right angle output IE2 drive systems

Dimensions

Dimensions of Multibloc (Mb) geared motors, MU universal mounting, Mb 2601 MUT LS

Dimensions in millimetres

- NU standard, H hollow shaft

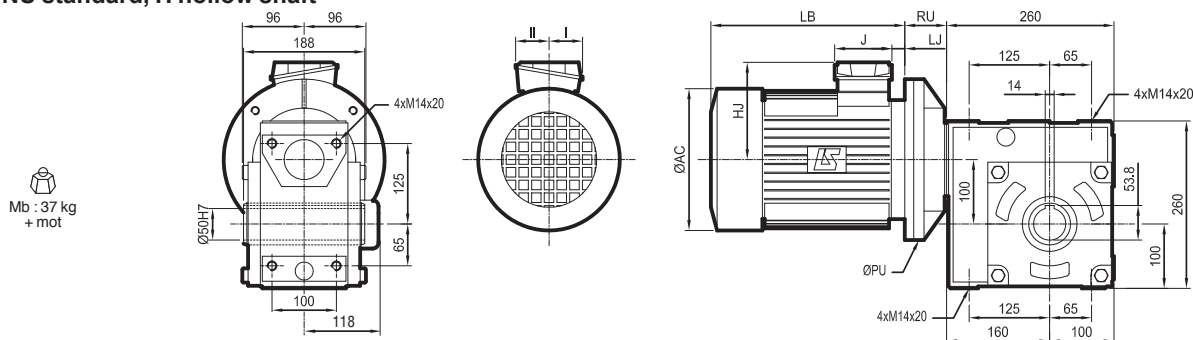

- BS¹ L* flange on left, H* hollow shaft

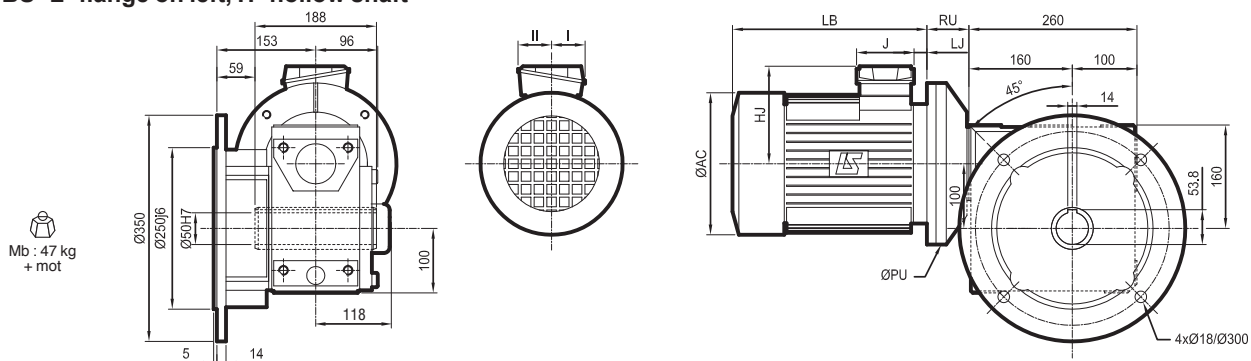

1. or BN flange: details page 30 * option on right BSR H: identical flange and shaft

- BT* form, H* hollow shaft

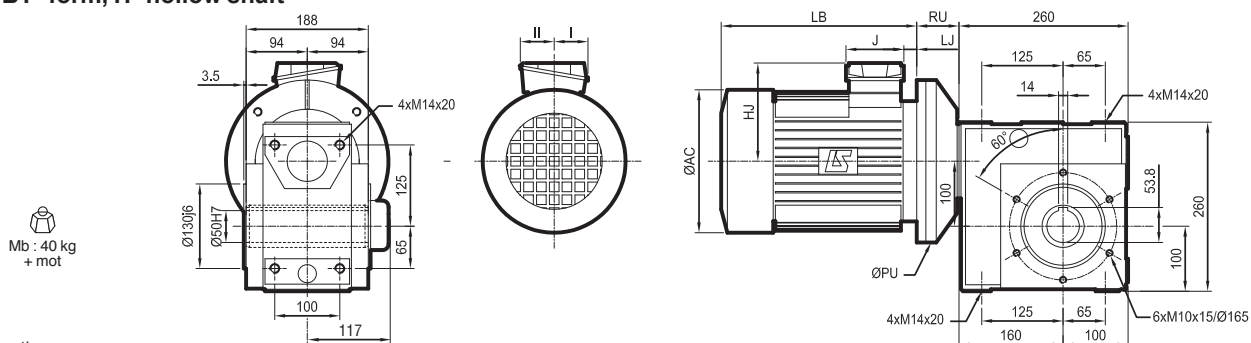

4 poles motors

Type	LSES MUT										kg	LSES FCR MUT										kg
	AC	HJ	J	LB	LJ	PU	RU	I	II	AC		HJ	J	LB	LJ	PU	RU	I	II			
LSES 100	235	140	86	309	27	250	51	43	43	29,2	200	161	160	363,5	21	250	51	55	55	33,5		
LSES 112	235	149	86	333	35,5	250	51	43	43	38,5	235	169	160	396	23	250	51	55	55	44,5		
LSES 132	265	190	126	412	17	250	51	63	63	71,5	280	188	160	493	25	250	51	55	55	78,5		

4, 8 poles motors

Type	LS 8 pole MUT										kg	LS FCR MUT										kg
	AC	HJ	J	LB	LJ	PU	RU	I	II	AC		HJ	J	LB	LJ	PU	RU	I	II			
LS 100L	200	138	86	290	26	250	51	43	60	26	200	161	160	351	21	250	51	55	55	33,5		
LS 112	200	138	86	290	26	250	51	43	60	28,4	235	169	160	396	23	250	51	55	55	44,5		
LS 132	280	175	110	387	25	250	51	57	73	63,5	280	188	160	493	25	250	51	55	55	78,5		

Std CEI

MULTIBLOC /LS, LSES geared motors with worm & wheel, right angle output IE2 drive systems

Dimensions

Dimensions of Multibloc (Mb) geared motors, MU universal mounting, Mb 3101

Dimensions in millimetres

- BN1 L* flange on left, HL* output shaft on left

Mb : 6 kg
+ mot

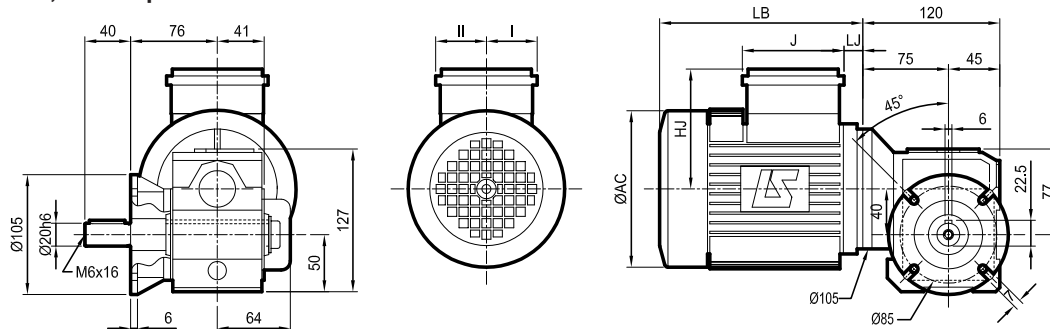

* option on right BN1 R HR: identical flange and shaft

- BN2 L* flange on left, HL* output shaft on left

Mb : 6.5 kg
+ mot

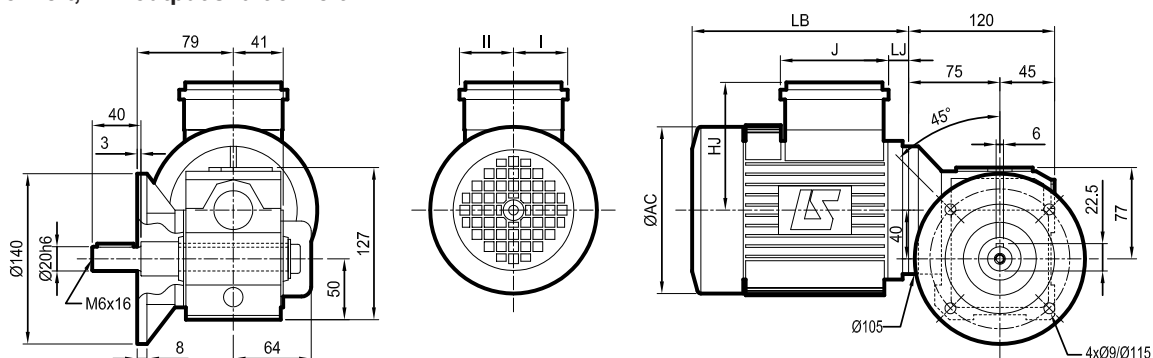

* option on right BN2 R RH: identical flange and shaft

- Details HLR

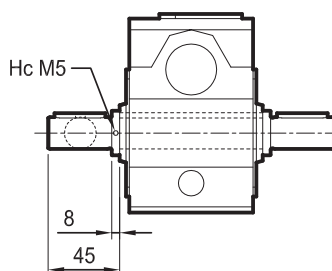

MULTIBLOC /LS, LSES geared motors with worm & wheel, right angle output IE2 drive systems

Dimensions

Dimensions of Multibloc (Mb) geared motors, MU universal mounting, Mb 3101 MUT LS

Dimensions in millimetres

- NU standard, HL¹ output shaft on left

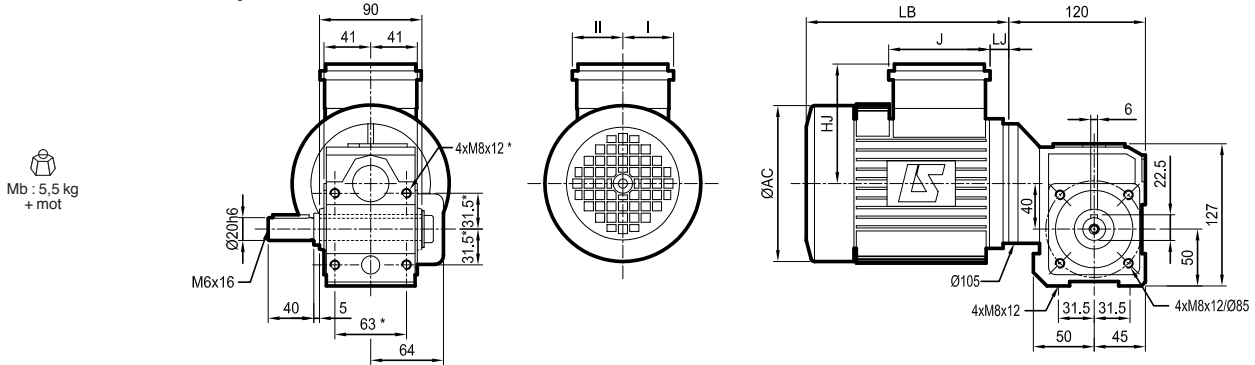

- BN¹ L* flange on left, HL* output shaft on left

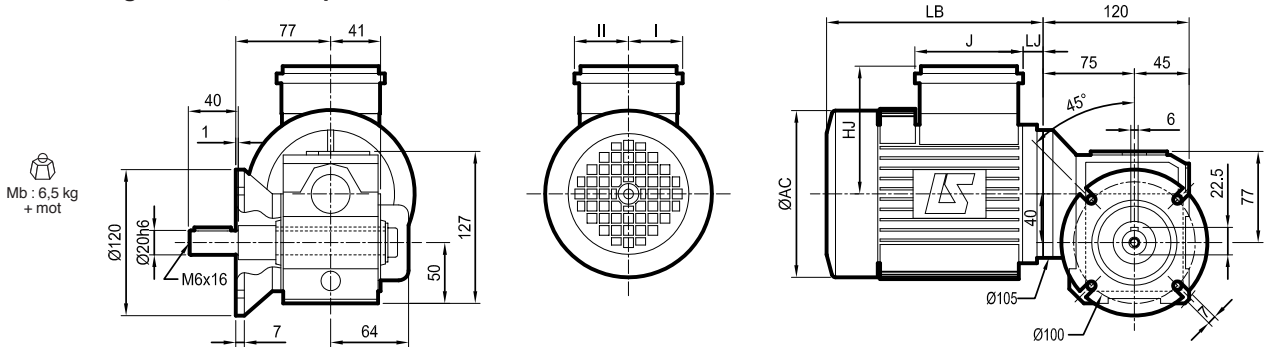

* option on right BNR HR: identical flange and shaft

Type	4 poles motors										kg	4 poles motors										kg
	LSES MUT					LSES FCR MUT						LSES FCR MUT										
	AC	HJ	J	LB	LJ	PU	RU	I	II	AC		HJ	J	LB	LJ	PU	RU	I	II			
LS 80	171	135	86	267	67,5	105	0	43	43	11,7	172	146	160	304	13	105	0	55	55	18		

Type	4, 8 poles motors										kg	4, 8 poles motors										kg
	LS MUT					LS FCR MUT						LS FCR MUT										
	AC	HJ	J	LB	LJ	PU	RU	I	II	AC		HJ	J	LB	LJ	PU	RU	I	II			
LS 71 L	140	99	86	193	26	105	0	43	43	8,3	140	135	160	245	13	105	0	55	55	11		
LS 80 L	-	-	-	-	-	-	-	-	-	-	172	146	160	300	46	105	0	55	55	18		

Std CEI

MULTIBLOC /LS, LSES geared motors with worm & wheel, right angle output IE2 drive systems

Dimensions

Dimensions of Multibloc (Mb) geared motors, MU universal mounting, Mb 2201 MUT LS

Dimensions in millimetres

- NU standard, HL¹ output shaft on left

Mb : 8,2 kg
+ mot

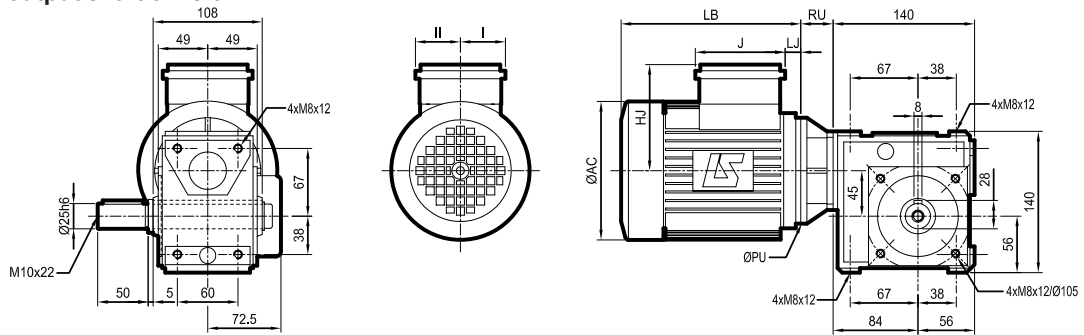

1. option : HR shaft on right

- BS¹ L* flange on left, HL* output shaft on left

Mb : 12 kg
+ mot

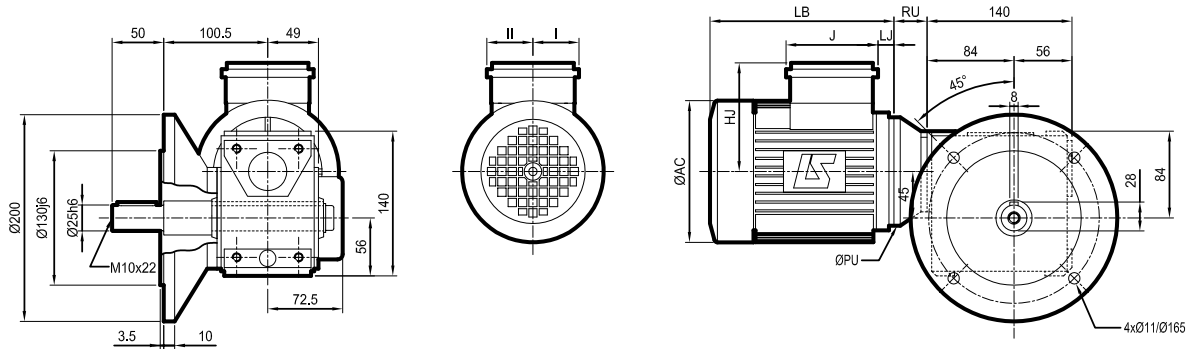

1. or BN flange: details page 34

* option on right BSR HR: identical flange and shaft

4 poles motors

Type	LSES MUT										kg	LSES FCR MUT										kg
	AC	HJ	J	LB	LJ	PU	RU	I	II			AC	HJ	J	LB	LJ	PU	RU	I	II		
LSES 80	183	135	86	267	26	120	33	43	43	12,7	184	156	160	304	13	120	33	55	55	25,2		
LSES 90	189	135	86	245	26	120	33	43	43	15,6	184	156	160	304	13	120	33	55	55	25,2		

4, 8 poles motors

Type	LS 71 - 4 poles ; LS 80 - 8 poles MUT										kg	LS FCR MUT										kg
	AC	HJ	J	LB	LJ	PU	RU	I	II			AC	HJ	J	LB	LJ	PU	RU	I	II		
LS 71 L	140	99	86	193	26	105	31	43	43	9	140	135	160	245	13	105	31	55	55	12		
LS 80 L	170	123	86	215	26	120	33	43	43	11,5	172	146	160	265	13	120	33	55	55	19,2		
LS 90 L	-	-	-	-	-	-	-	-	-	-	184	156	160	304	13	120	33	55	55	25,2		

Std CEI

MULTIBLOC /LS, LSES geared motors with worm & wheel, right angle output IE2 drive systems

Dimensions

Dimensions of Multibloc (Mb) geared motors, MU universal mounting, Mb 2301 MUT LS

Dimensions in millimetres

- NU standard, HL¹ output shaft on left

Mb : 11,7 kg
+ mot

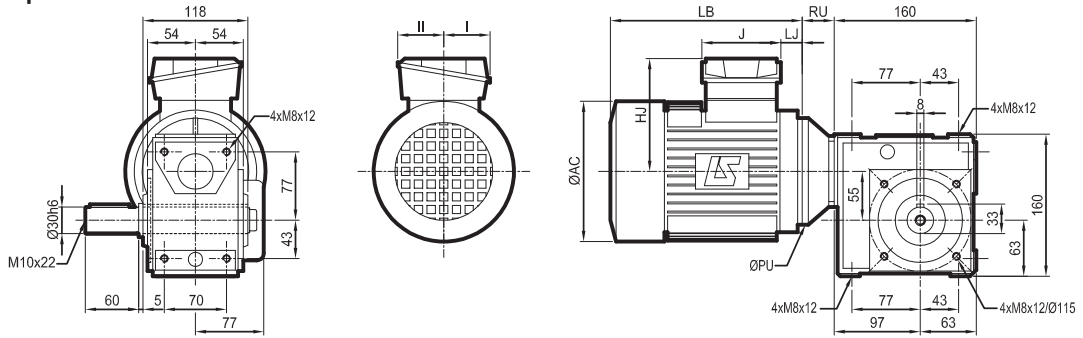

1. option: HR shaft on right

- BS¹ L* flange on left, HL* output shaft on left

Mb : 15 kg
+ mot

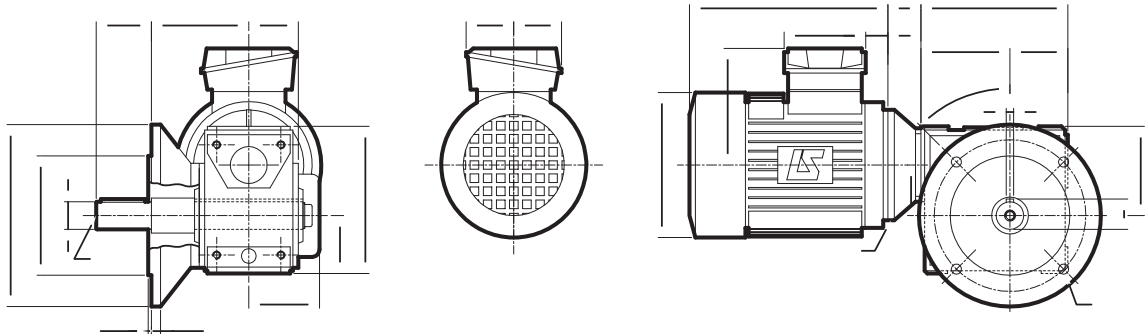

1. or BN flange: details page 36

* option on right BSR HR: identical flange and shaft

4 poles motors

Type	LSES MUT										kg	LSES FCR MUT										kg
	AC	HJ	J	LB	LJ	PU	RU	I	II			AC	HJ	J	LB	LJ	PU	RU	I	II		
LSES 80	183	135	86	267	26	120	36	43	43	12,7	190	156	160	304	13	120	36	55	55	25,2		
LSES 90	190	135	86	245	26	140	38	43	43	16,7	190	156	160	304	13	140	38	55	55	25,2		
LSES 100	235	140	86	309	27	140	35	43	43	26,7	200	161	160	364,5	21	140	35	55	55	31		
LSES 112	235	149	86	333	35,5	140	38	43	43	36	235	169	160	396	23,5	140	38	55	55	42		

4, 8 poles motors

Type	LS 71 - 4 poles ; LS 80 and 90 - 8 poles MUT										kg	LS FCR MUT										kg
	AC	HJ	J	LB	LJ	PU	RU	I	II			AC	HJ	J	LB	LJ	PU	RU	I	II		
LS 71 L	140	99	86	193	26	105	35	43	43	9,2	140	135	160	245	13	105	35	55	55	12		
LS 80 L	170	123	86	215	26	120	36	43	60	12	172	146	160	265	13	120	36	55	55	19,2		
LS 90 L	190	133	86	245	26	140	36	43	60	16	190	156	160	304	13	140	38	55	55	25,2		
LS 100 L	-	-	-	-	-	-	-	-	-	-	200	161	160	351	21	140	35	55	55	31		
LS 112	-	-	-	-	-	-	-	-	-	-	235	169	160	396	23,5	140	38	55	55	42		

Std CEI

MULTIBLOC /LS, LSES geared motors with worm & wheel, right angle output IE2 drive systems

Dimensions

Dimensions of Multibloc (Mb) geared motors, MU universal mounting, Mb 2401 MUF LS

Dimensions in millimetres

- BDL* flange on left, HL* output shaft on left

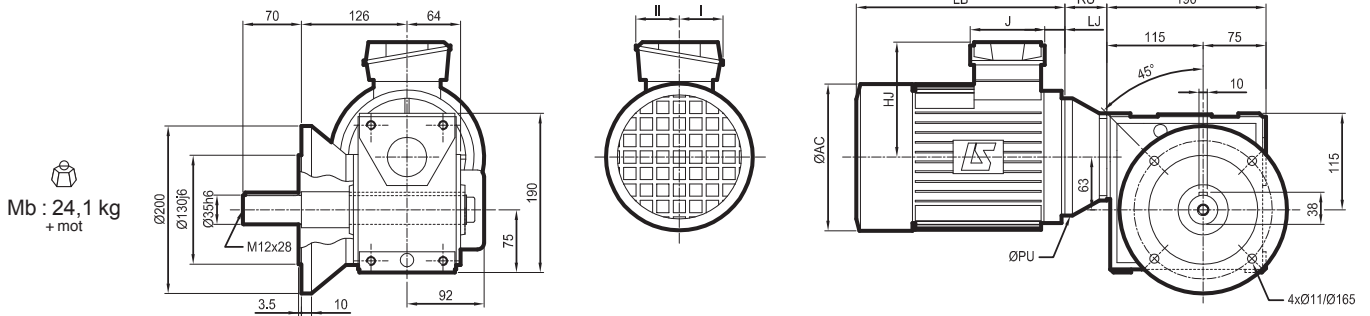

* option on right BDR HR: identical flange and shaft

- NSD* baseplate, HL¹ output shaft on left

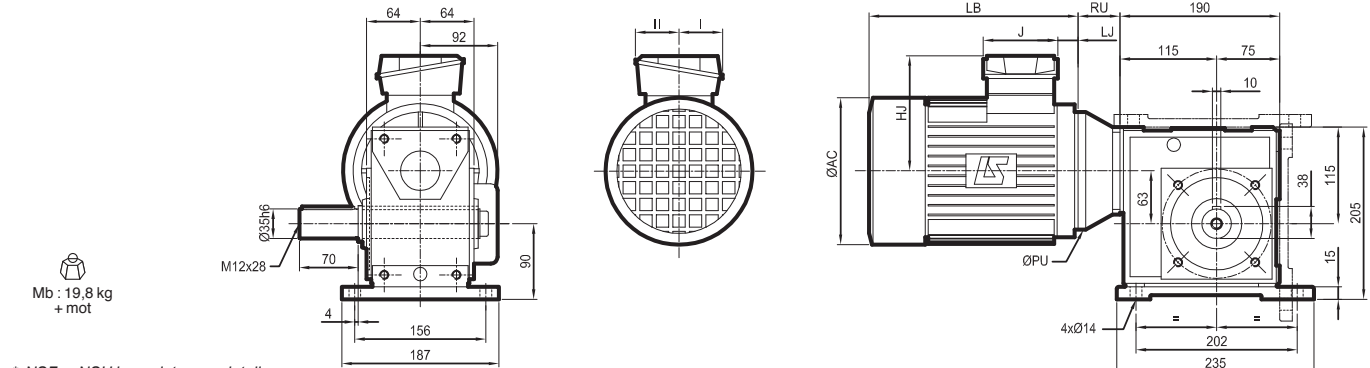

* NSF or NSU baseplate, see details
1. option: HR shaft on right

- Details

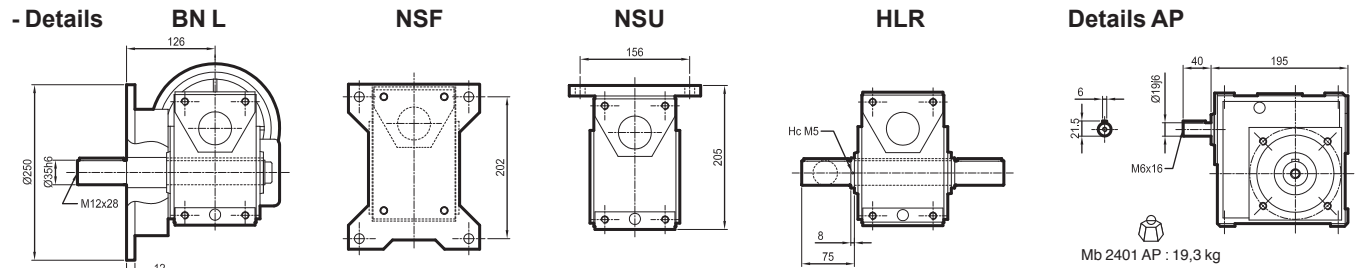

Type	4 poles motors										kg									
	LSES MUF					LSES FCR MUF														
	AC	HJ	J	LB	LJ	PU	RU	I	II											
LSSES 80	183	135	86	247	26	200	50	43	43	14,7	184	156	160	324	33	200	50	55	55	27,2
LSSES 90	190	135	86	265	46	200	50	43	43	17,6	184	156	160	324	33	200	50	55	55	27,2
LSSES 100	235	140	86	309	27	250	50	43	43	28,7	200	161	160	400,5	50	250	50	55	55	33
LSSES 112	235	149	86	333	35,5	250	50	43	43	38	235	165	160	396	23,5	250	50	55	55	44
LSSES 132	220	172	126	377	32,5	250	50	63	63	45	235	169	160	457	41	250	50	55	55	51

Type	4, 8 poles motors										kg									
	LS 71 - 4 poles ; LS 8 poles MUF					LS FCR MUF														
	AC	HJ	J	LB	LJ	PU	RU	I	II											
LS 71 L	140	99	86	193	21	160	50	43	43	11,3	140	135	160	271	38	160	50	55	55	14
LS 80 L	170	123	86	215	26	200	50	43	60	14	172	146	160	292	38	200	50	55	55	21,2
LS 90 L	190	133	86	265	46	200	50	43	60	18,2	184	156	160	324	33	200	50	55	55	27,2
LS 100 L	200	138	86	290	26	250	50	43	60	25,5	200	161	160	388	50	250	50	55	55	33
LS 112	-	-	-	-	-	-	-	-	-	-	235	169	160	425	49	250	50	55	55	44
LS 132 S	-	-	-	-	-	-	-	-	-	-	235	169	160	437	41	250	50	55	55	51

Std CEI

MULTIBLOC /LS, LSES geared motors with worm & wheel, right angle output IE2 drive systems

Dimensions

Dimensions of Multibloc (Mb) geared motors, MU universal mounting, Mb 2401 MUT LS

Dimensions in millimetres

- NU standard, HL¹ output shaft on left

Mb : 19,3 kg + mot

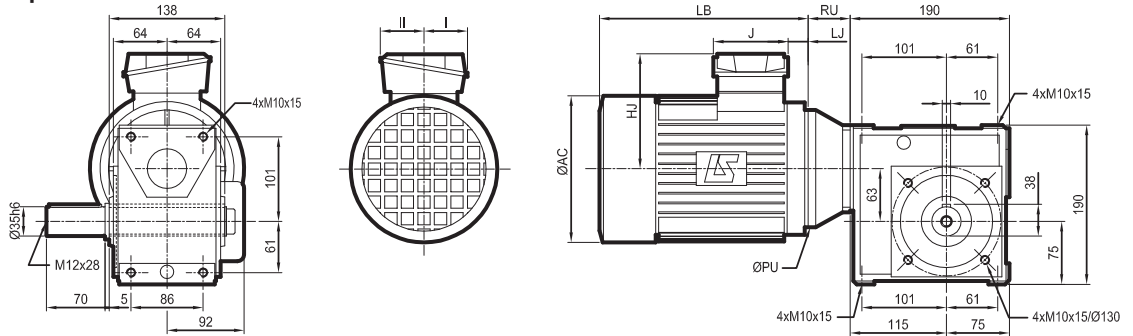

1. option: HR shaft on right

- BS¹ L* flange on left, HL* output shaft on left

Mb : 24,9 kg + mot

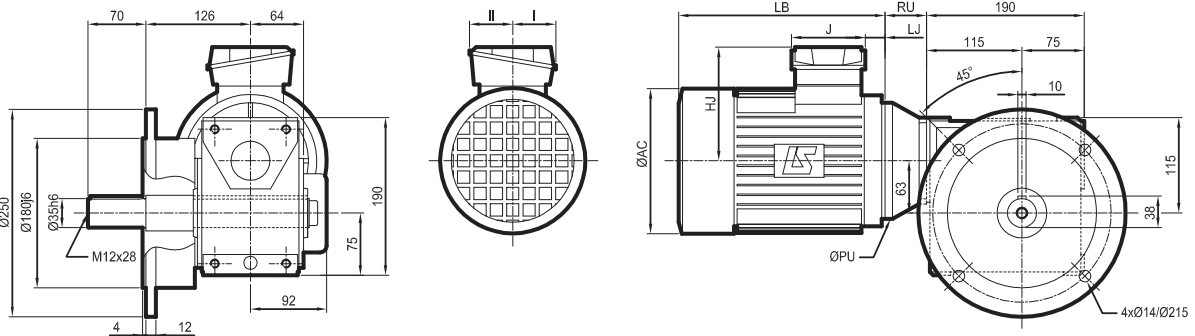

1. or BN flange: details page 38

* option on right BSR HR: identical flange and shaft

4 poles motors

Type	LSES MUT										kg	LSES FCR MUT										kg
	AC	HJ	J	LB	LJ	PU	RU	I	II			AC	HJ	J	LB	LJ	PU	RU	I	II		
LSES 80	183	135	86	267	26	120	50	43	43	13,5	184	156	160	304	13	120	50	55	55	26		
LSES 90	190	135	86	245	26	140	50	43	43	16,4	184	156	160	304	13	140	50	55	55	26		
LSES 100	235	140	86	309	27	160	50	43	43	27,5	200	161	160	364,5	21	160	50	55	55	31,8		
LSES 112	235	149	86	333	35,5	160	50	43	43	36,8	235	169	160	396	23	160	50	55	55	42,8		
LSES 132	220	172	126	377	32	160	50	63	63	43,8	235	169	160	457	41	160	50	55	55	43,8		

4, 8 poles motors

Type	LS 8 poles MUT										kg	LS FCR MUT										kg
	AC	HJ	J	LB	LJ	PU	RU	I	II			AC	HJ	J	LB	LJ	PU	RU	I	II		
LS 80 L	170	123	86	215	26	120	50	43	60	12,7	172	146	160	265	13	120	50	55	55	20		
LS 90 L	190	133	86	245	26	140	50	43	60	17	184	156	160	304	13	140	50	55	55	26		
LS 100 L	200	138	86	290	26	160	50	43	60	24,3	200	161	160	351	21	160	50	55	55	31,8		
LS 112	-	-	-	-	-	-	-	-	-	-	235	169	160	396	23	160	50	55	55	42,8		
LS 132 S	-	-	-	-	-	-	-	-	-	-	235	169	160	437	41	160	50	55	55	43,8		

Std CEI

MULTIBLOC /LS, LSES geared motors with worm & wheel, right angle output IE2 drive systems

Dimensions

Dimensions of Multibloc (Mb) geared motors, MU universal mounting, Mb 2501 MUF LS

Dimensions in millimetres

- BDL* flange on left, HL* output shaft on left

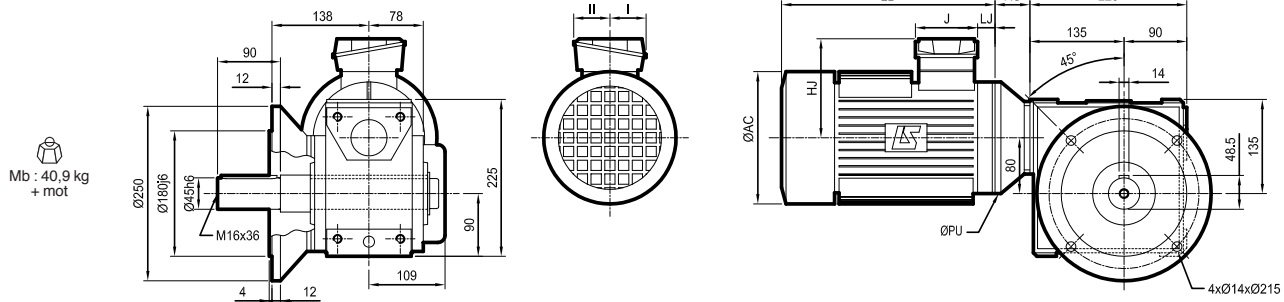

Mb : 40,9 kg + mot

* option on right BDR HR: identical flange and shaft

- NSD* baseplate, HL¹ output shaft on left

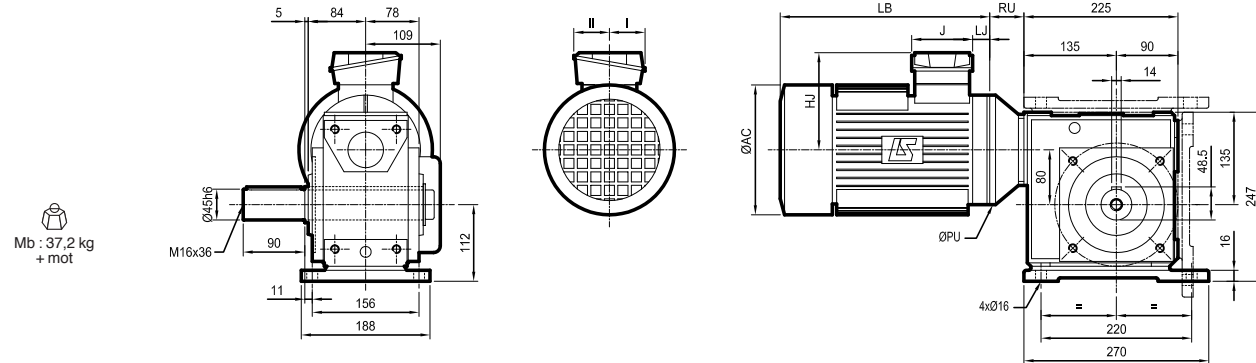

Mb : 37,2 kg + mot

* NSF or NSU baseplate, see details
1. option: HR shaft on right

- Details

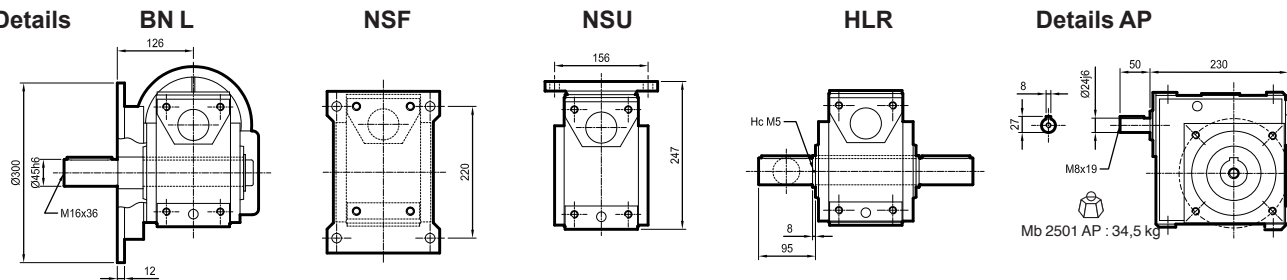

Type	4 poles motors										kg	4 poles motors										kg
	LSES MUF					LSES FCR MUF						LSES FCR MUF										
	AC	HJ	J	LB	LJ	PU	RU	I	II		AC	HJ	J	LB	LJ	PU	RU	I	II			
LS 80	183	135	86	247	26	200	50	43	43	14,7	184	156	160	324	38	200	50	55	55	27,2		
LS 90	190	135	86	265	46	200	50	43	43	17,6	184	156	160	324	33	200	50	55	55	27,2		
LS 100	235	140	86	309	27	250	50	43	43	28,7	200	161	160	400,5	50	250	50	55	55	33		
LS 112	235	149	86	333	35,5	250	50	43	43	38	235	169	160	425	49	250	50	55	55	44		
LS 132	265	190	126	412	17	250	50	63	63	71	280	188	160	533	65	250	50	55	55	78		

Type	4, 8 poles motors										kg	4, 8 poles motors										kg
	LS 8 pole MUF					LS 8 pole MUF						LS FCR MUF										
	AC	HJ	J	LB	LJ	PU	RU	I	II		AC	HJ	J	LB	LJ	PU	RU	I	II			
LS 80 L	-	-	-	-	-	-	-	-	-	-	172	146	160	292	38	200	50	55	55	21,2		
LS 90 L	190	133	86	265	46	200	50	43	60	18,4	184	156	160	324	33	200	50	55	55	27,2		
LS 100 L	200	138	86	290	26	250	50	43	60	25,6	200	161	160	388	50	250	50	55	55	33		
LS 112	200	138	86	290	26	250	50	43	60	27,9	235	169	160	425	49	250	50	55	55	44		
LS 132	-	-	-	-	-	-	-	-	-	-	280	188	160	533	65	250	50	55	55	78		

Std CEI

MULTIBLOC /LS, LSES geared motors with worm & wheel, right angle output IE2 drive systems

Dimensions

Dimensions of Multibloc (Mb) geared motors, MU universal mounting, Mb 2501 MUT LS

Dimensions in millimetres

- NU standard, HL¹ output shaft on left

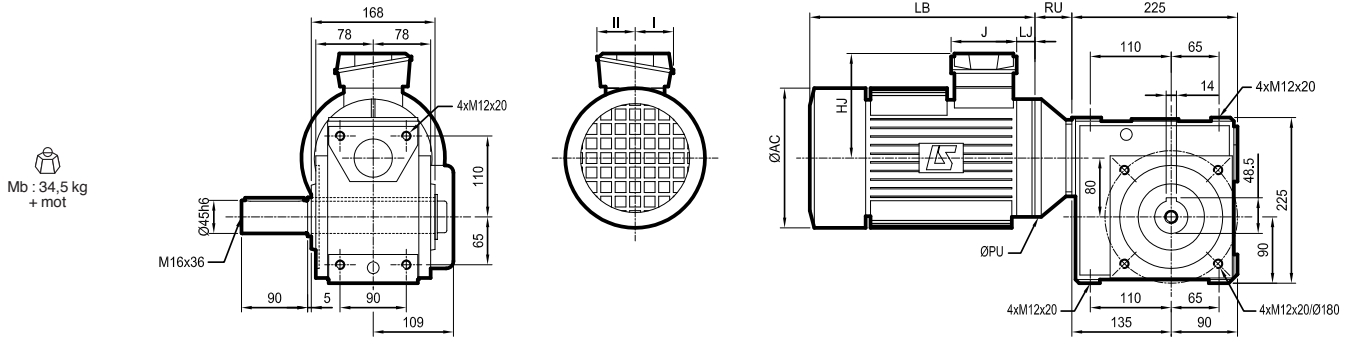

1. option: HR shaft on right

- BS¹ L* flange on left, H* hollow shaft

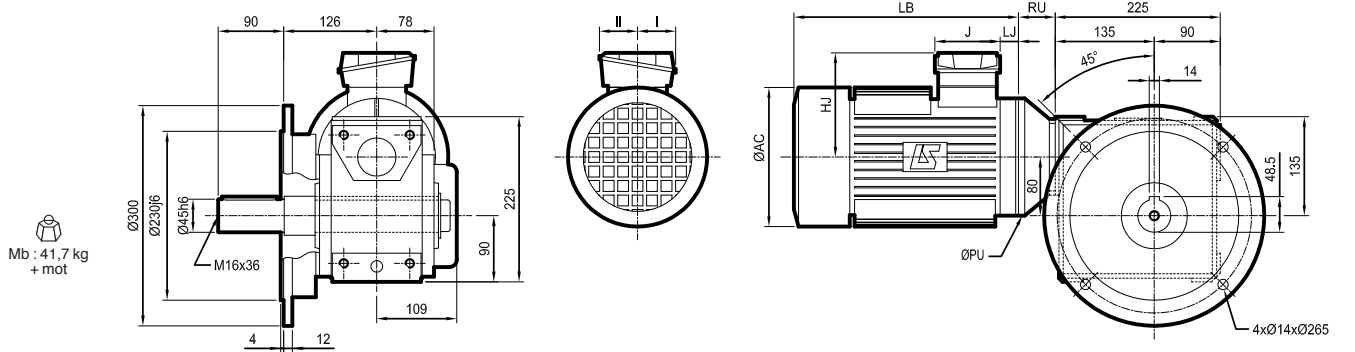

1. or BN flange: details page 40

* option on right BSR HR: identical flange and shaft

Type	4 poles motors										kg	4 poles motors										kg
	LSES MUT					kg	LSES FCR MUT					kg										
	AC	HJ	J	LB	LJ		PU	RU	I	II			AC	HJ	J	LB	LJ	PU	RU	I	II	
LSES 80	183	135	86	247	26	120	50	43	43	13,5	190	156	160	304	13	120	50	55	55	26		
LSES 90	190	135	86	245	26	140	50	43	43	16,4	190	156	160	304	13	140	50	55	55	26		
LSES 100	235	140	86	309	27	160	50	43	43	27,5	200	161	160	363,5	21	160	50	55	55	31,8		
LSES 112	235	149	86	333	35,5	160	50	43	43	36,8	235	169	160	396	23	160	50	55	55	42,8		
LSES 132	265	190	126	412	17	160	50	43	43	69,8	280	188	160	493	25	160	50	55	55	76,8		

Type	4, 8 poles motors										kg	4, 8 poles motors										kg
	LS 8 pole MUT					kg	LS FCR MUT					kg										
	AC	HJ	J	LB	LJ		PU	RU	I	II			AC	HJ	J	LB	LJ	PU	RU	I	II	
LS 80 L	-	-	-	-	-	-	-	-	-	-	172	146	160	265	13	120	50	55	55	20		
LS 90 L	190	133	86	245	26	140	50	43	60	17	184	156	160	304	13	140	50	55	55	26		
LS 100 L	200	138	86	290	26	160	50	43	60	24,3	200	161	160	351	21	160	50	55	55	31,8		
LS 112	200	138	86	290	26	160	50	43	60	26,7	235	169	160	396	23	160	50	55	55	42,8		
LS 132	-	-	-	-	-	-	-	-	-	-	280	188	160	493	25	160	50	55	55	76,8		

Std CEI

MULTIBLOC /LS, LSES geared motors with worm & wheel, right angle output IE2 drive systems

Dimensions

Dimensions of Multibloc (Mb) geared motors, MU universal mounting, Mb 2601 MUF LS

Dimensions in millimetres

- BDL* flange on left, HL* output shaft on left

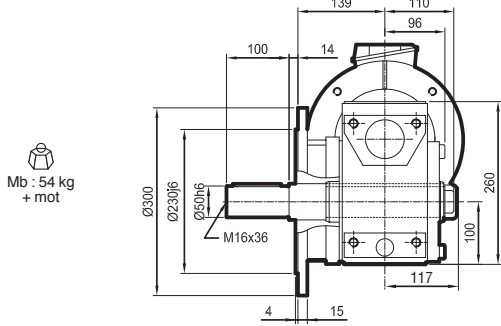

Mb : 54 kg + mot

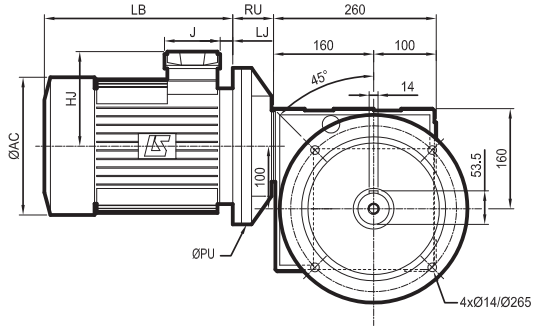
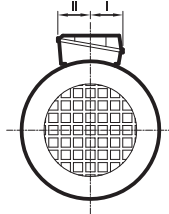

* option on right BDR HR: identical flange and shaft

- NSD* baseplate, HL¹ output shaft on left

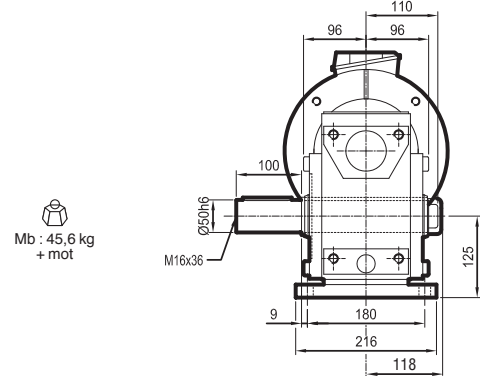

Mb : 45.6 kg + mot

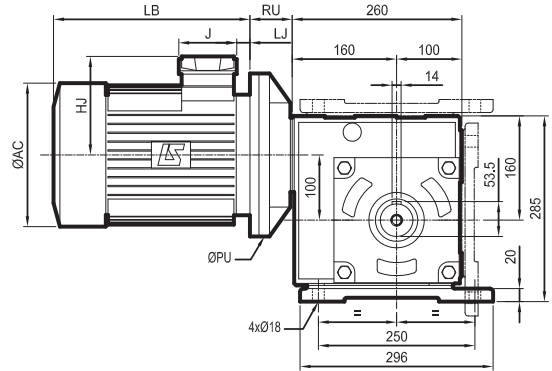
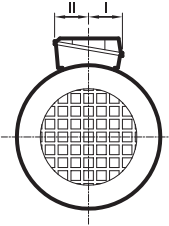

* NSF or NSU baseplate, see details 1. option : HR shaft on right

- Details

BN L

NSF

NSU

HLR

Details AP

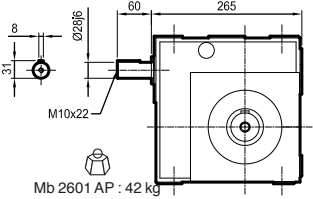
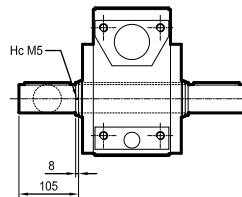
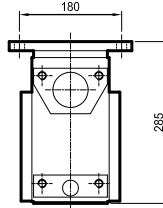
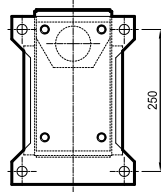
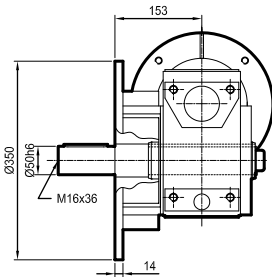

4 poles motors

Type	LSES MUF										kg	LSES FCR MUF										kg
	AC	HJ	J	LB	LJ	PU	RU	I	II	AC		HJ	J	LB	LJ	PU	RU	I	II			
LSSES 90	190	135	86	265	46	200	59	43	43	18,2	184	156	160	324	33	200	59	55	55	27,8		
LSSES 100	235	140	86	309	27	250	51	43	43	29,3	200	161	160	400,5	50	250	51	55	55	33,6		
LSSES 112	235	149	86	333	35,5	250	51	43	43	38	235	169	160	425	49	250	51	55	55	44,6		
LSSES 132	265	190	126	452	57	250	51	63	63	71	280	188	160	533	65	250	51	55	55	78,6		

4, 8 poles motors

Type	LS 8 pole MUF										kg	LS FCR MUF										kg
	AC	HJ	J	LB	LJ	PU	RU	I	II	AC		HJ	J	LB	LJ	PU	RU	I	II			
LS 90L	190	133	86	265	46	200	59	43	60	18,8	184	156	160	324	33	200	59	55	55	27,8		
LS 100L	200	138	86	290	26	250	51	43	60	26	200	161	160	388	50	250	51	55	55	33,6		
LS 112	200	138	86	290	26	250	51	43	60	28,5	235	169	160	425	49	250	51	55	55	44,6		
LS 132	280	175	110	387	25	250	51	57	73	63,5	280	188	160	533	65	250	51	55	55	78,6		

Std CEI

MULTIBLOC /LS, LSES geared motors with worm & wheel, right angle output IE2 drive systems

Dimensions

Dimensions of Multibloc (Mb) geared motors, MU universal mounting, Mb 2601 MUT LS

Dimensions in millimetres

- NU standard, HL¹ output shaft on left

Mb : 41,9 kg + mot

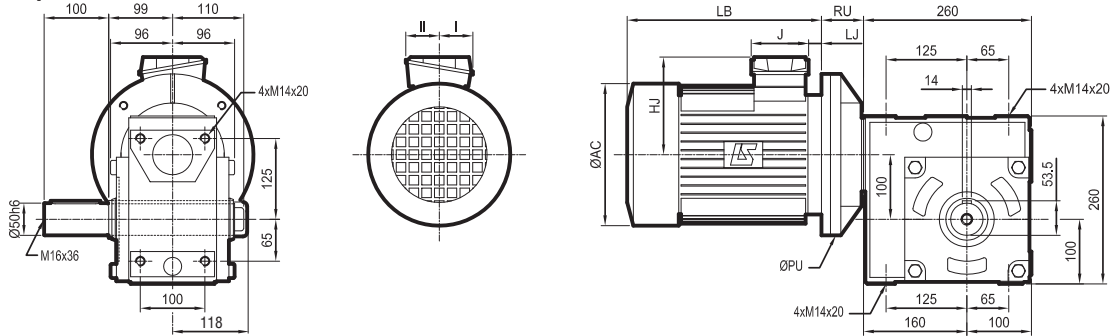

1. option: HR shaft on right

- BS¹ L* flange on left, HL* output shaft on left

Mb : 52,9 kg + mot

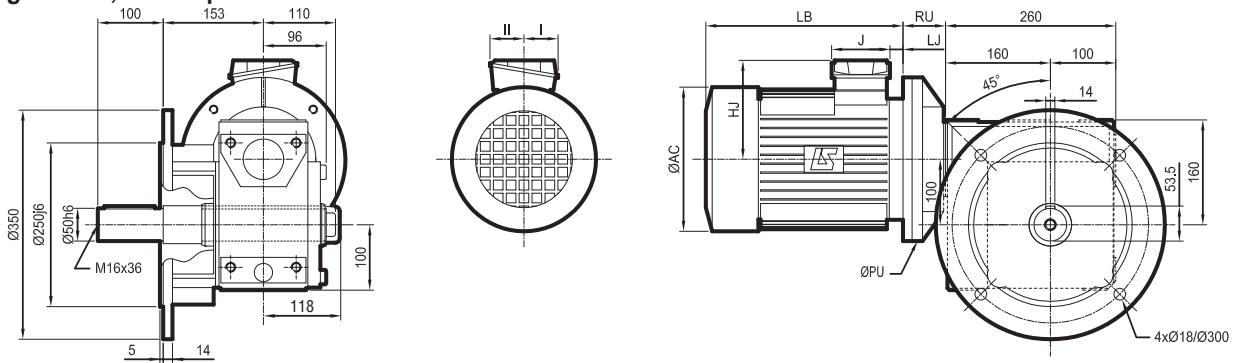

1. or BN flange: details page 42

* option on right BSR HR: identical flange and shaft

4 poles motors

Type	LSES MUT										kg	LSES FCR MUT										kg
	AC	HJ	J	LB	LJ	PU	RU	I	II	AC		HJ	J	LB	LJ	PU	RU	I	II			
LSES 100	235	140	86	309	27	250	51	43	43	29,2	200	161	160	363,5	21	250	51	55	55	33,5		
LSES 112	235	149	86	333	35,5	250	51	43	43	38,5	235	169	160	396	23	250	51	55	55	44,5		
LSES 132	265	190	126	412	17	250	51	63	63	71,5	280	188	160	493	25	250	51	55	55	78,5		

4, 8 poles motors

Type	LS 8 pole MUT										kg	LS FCR MUT										kg
	AC	HJ	J	LB	LJ	PU	RU	I	II	AC		HJ	J	LB	LJ	PU	RU	I	II			
LS 100L	200	138	86	290	26	250	51	43	60	26	200	161	160	351	21	250	51	55	55	33,5		
LS 112	200	138	86	290	26	250	51	43	60	28,4	235	169	160	396	23	250	51	55	55	44,5		
LS 132	280	175	110	387	25	250	51	57	73	63,5	280	188	160	493	25	250	51	55	55	78,5		

Std CEI

MULTIBLOC /LS, LSES geared motors with worm & wheel, right angle output IE2 drive systems

Dimensions

Dimensions of R torque arm, Mb 3101 and Mb 2201 to Mb 2501

Dimensions in millimetres

- Mb 2201 to 2501: R LD form (or R RD)

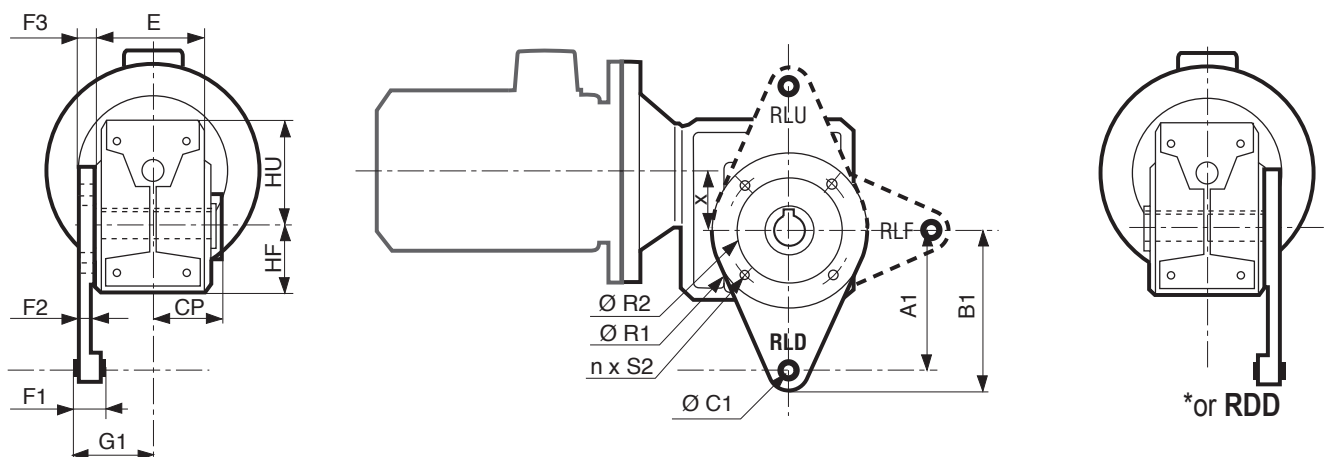

- Mb 3101: R LD form (or R RD)

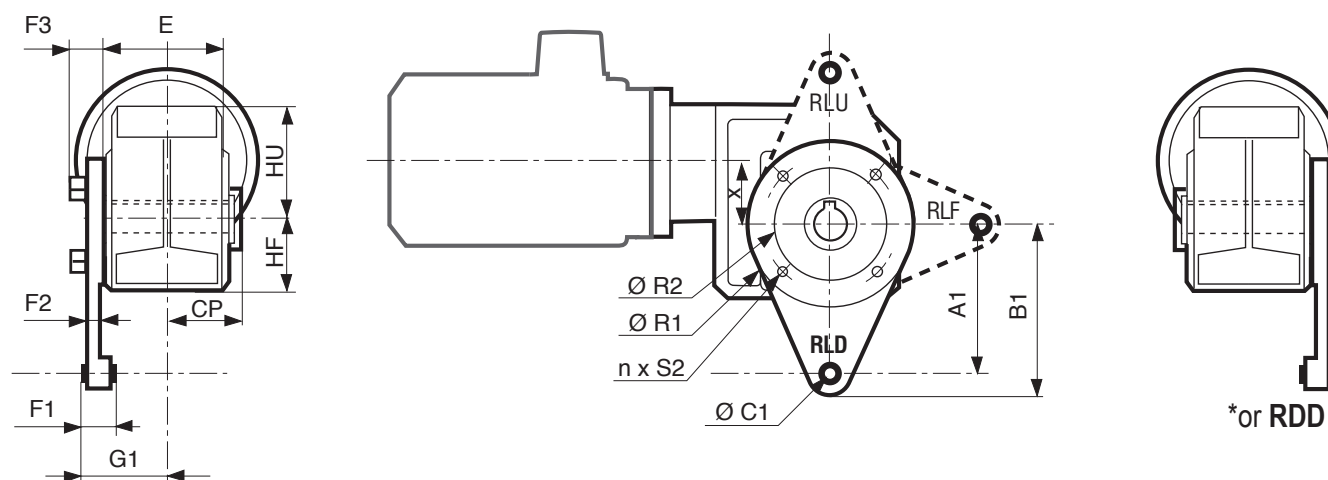

Type ¹	R torque arm																kg
	A1	B1	CP	C1	E	F1	F2	F3	G1	HF	HU	R1	R2	n	S2	x	
Mb 2501	310	340	28,5	16 H10	168	54	23	25	105	90	135	225	135	4	M12 x 25	80	6,7
Mb 2401	200	230	28	16 H10	138	54	23	25	91	75	115	179	97	4	M10 x 25	63	4,3
Mb 2301	160	181	22,5	10 H10	118	33	14	16	71,5	63	97	153	86	4	M8 x 15	55	1,8
Mb 2201	130	151	23,5	10 H10	108	33	14	16	66,5	56	84	133	77	4	M8 x 15	45	1,4
Mb 3101	100	120	22,5	10 H10	90	23	6	11,5	48,5	50	70	109	68	4	M8 x 20	40	0,5

1. In standard version, the torque arm (fitted with a flexible Silentbloc shock mount) is supplied separately, painted in black. Optionally, the torque arm is supplied mounted on the gearbox: in this case specify R (right) or L (left) mounting side and D, F or U orientation.

MULTIBLOC /LS, LSES geared motors with worm & wheel, right angle output IE2 drive systems

Notes

MULTIBLOC /LS, LSES geared motors with worm & wheel, right angle output IE2 drive systems

Notes

www.emersonindustrial.com

EMERSON. CONSIDER IT SOLVED.™



© Emerson 2014. The information contained in this brochure is for guidance only and does not form part of any contract. The accuracy cannot be guaranteed as Emerson have an ongoing process of development and reserve the right to change the specification of their products without notice.

Moteurs Leroy-Somer SAS. Siège social: Bd Marcellin Leroy, CS 10015, 16915 Angoulême Cedex 9, France. Capital social: 656 800 512 €, RCS Angoulême 338 567 258.

4808 en - 2014.07 / c